

CONDENSER COMPONENTS

AC23T-01

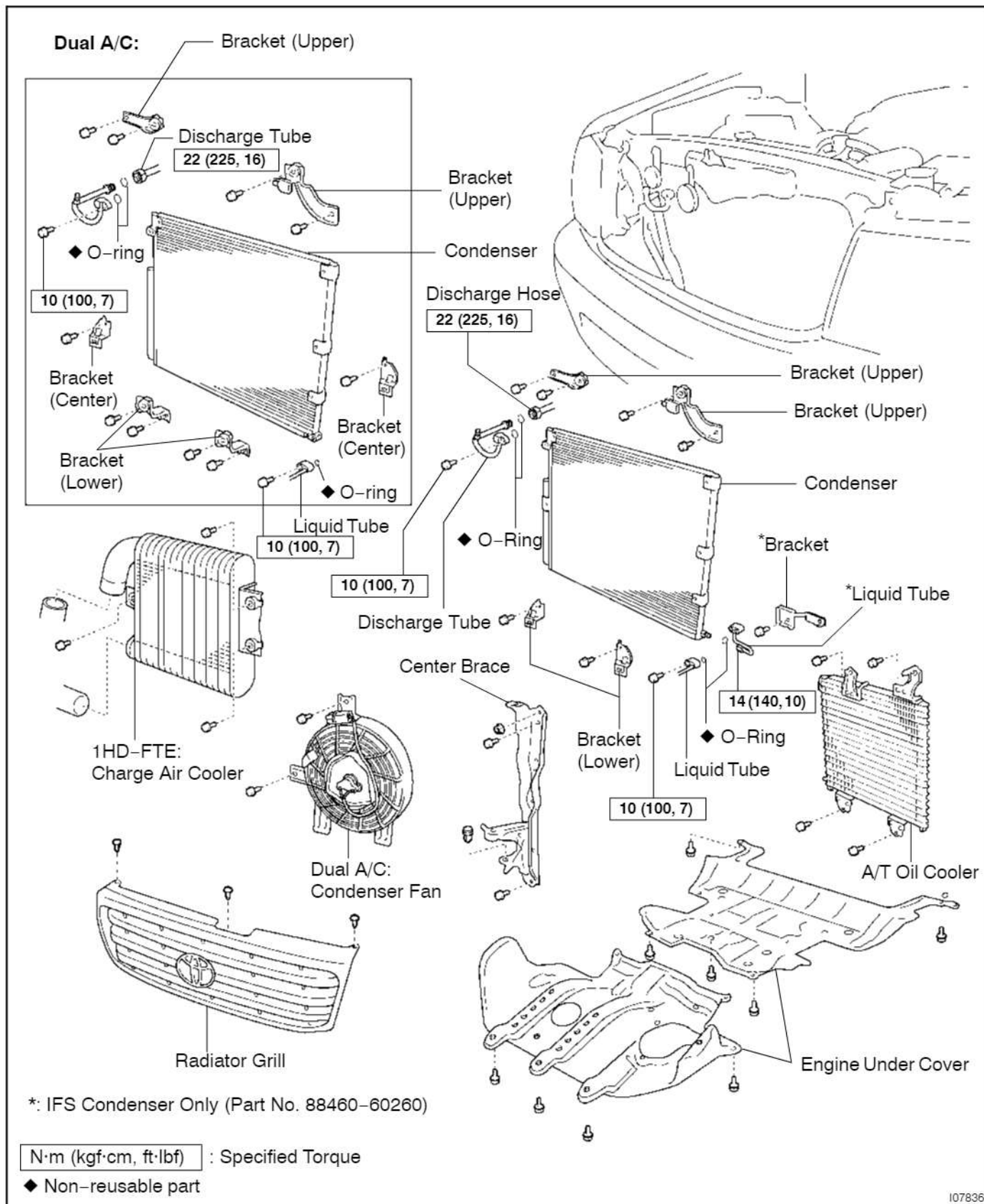

cardiagn.com

107836

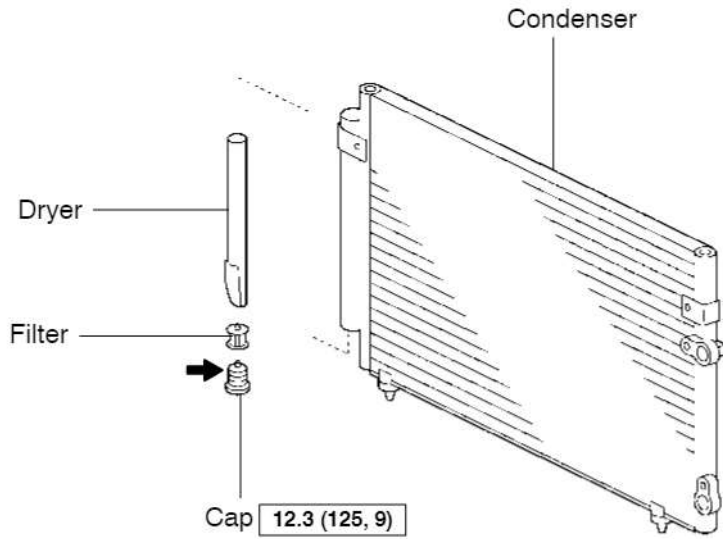

N·m (kgf·cm, ft·lbf) : Specified torque

← Compressor oil ND-OIL 8 or equivalent

109252

cardiagn.com

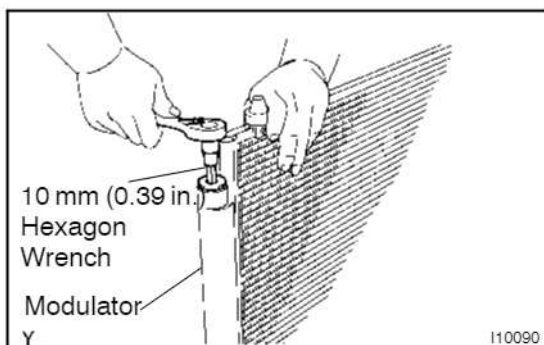

REPLACEMENT

REPLACE DRYER FROM MODULATOR

- (a) Using a hexagon wrench (10 mm, 0.39 in.), remove the cap from the modulator.
- (b) Remove the filter from the modulator.

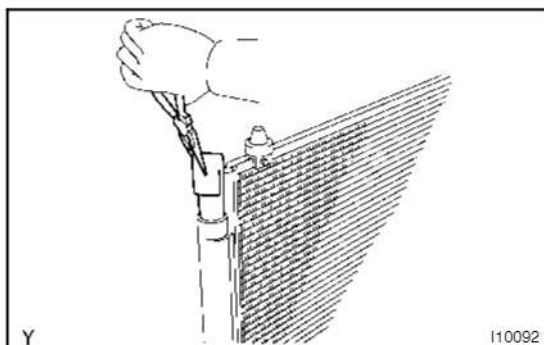

- (c) Using pliers, remove the dryer.

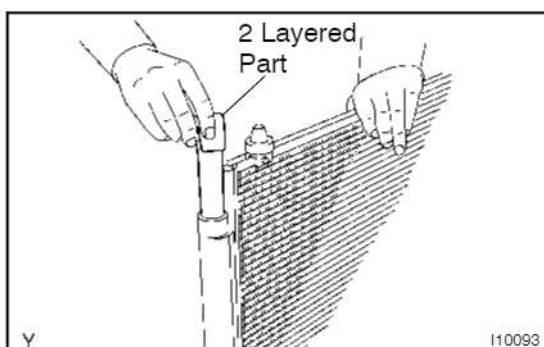

- (d) Insert a new dryer into the modulator.

NOTICE:

- Do not remove the dryer from a vinyl bag until inserting it into the modulator.
- Install the dryer with its 2 layered part faced upward to the modulator.

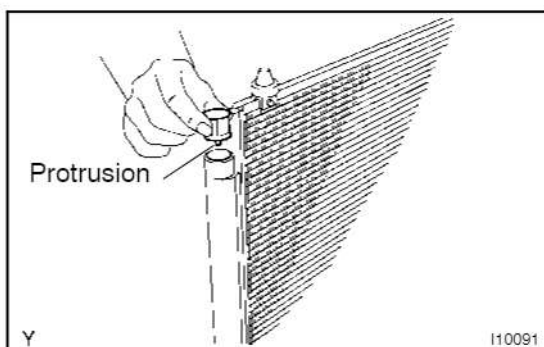

- (e) Insert the filter into the modulator.

NOTICE:

Install the filter with its protrusion faced downward to the modulator.

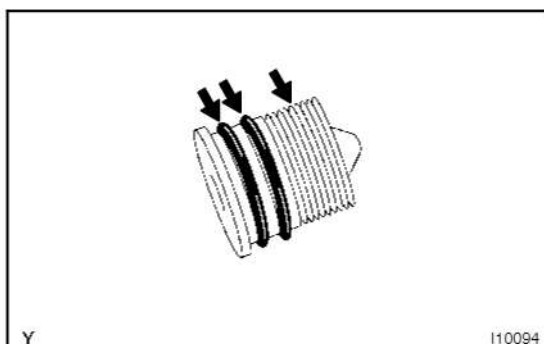

- (f) Install the cap to the modulator.
 - (1) Apply compressor oil to the O-rings and screw part of the cap.

Compressor oil: ND-OIL 8 or equivalent

- (2) Using a hexagon wrench (10 mm, 0.39 in.), install the caps.

Torque: 12.3 N·m (125 kgf·cm, 9 ft·lbf)



FRONT BUMPER COMPONENTS

801TL-02

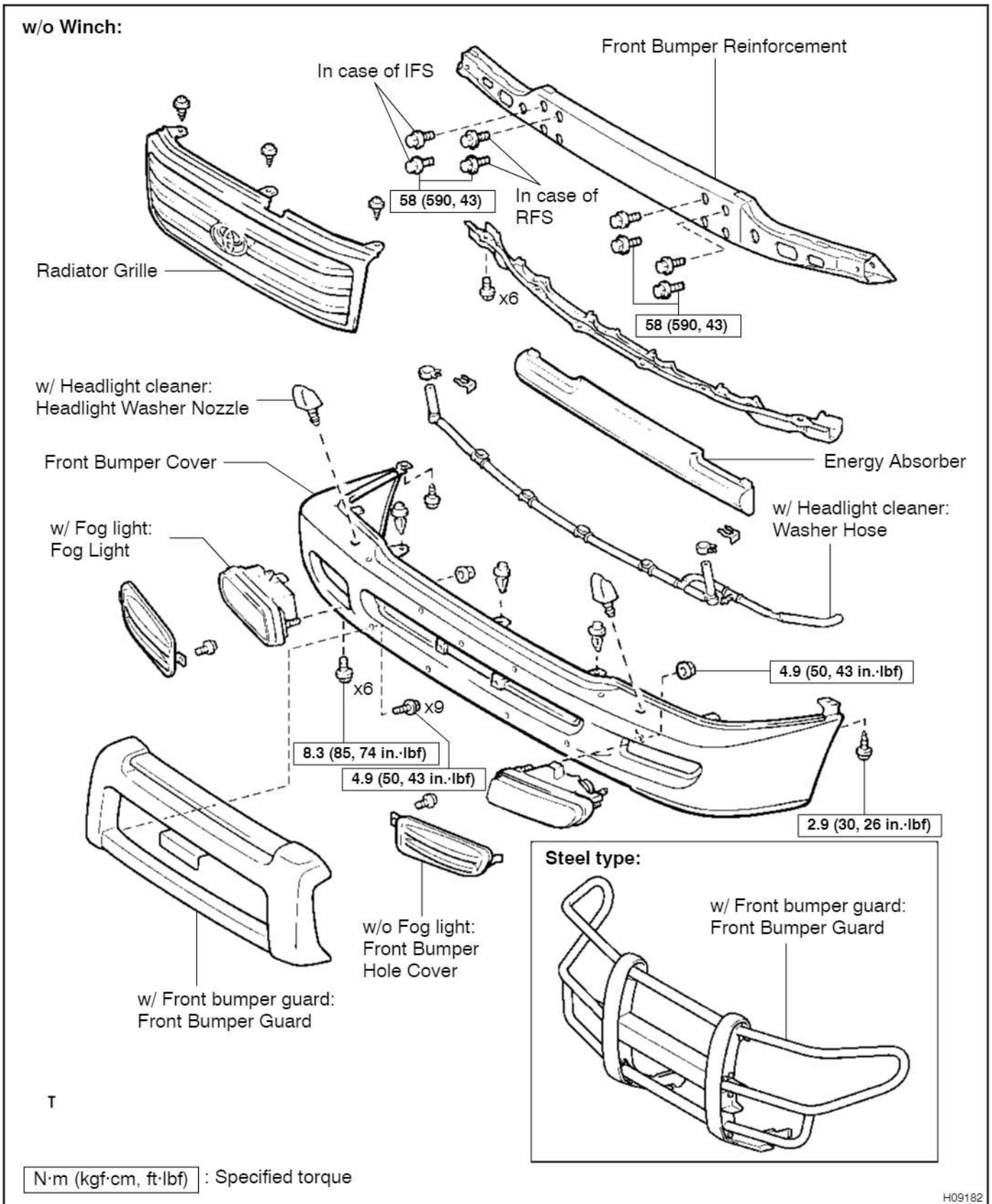

cardiagn.com

H09182

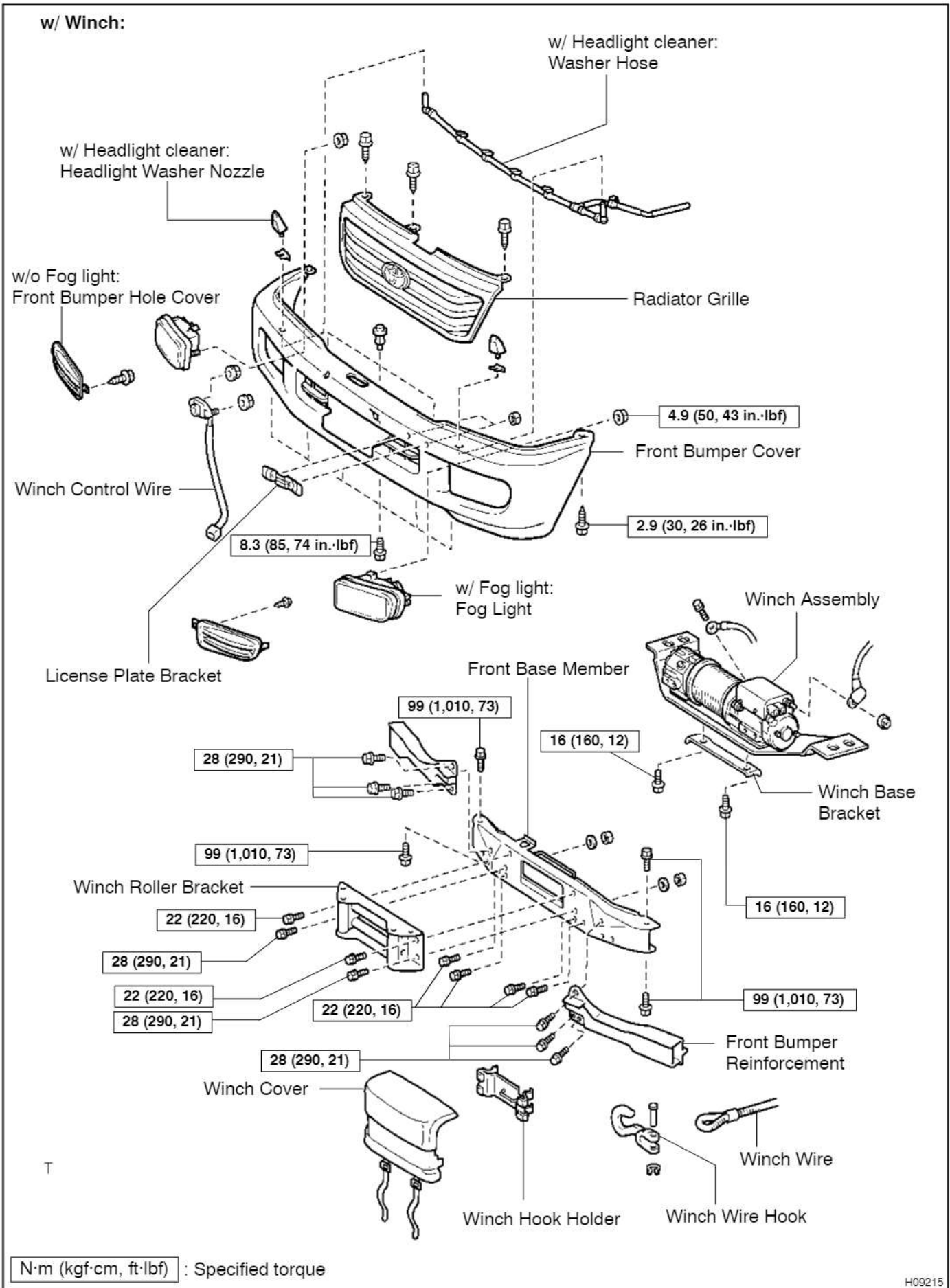

cardiagn.com

REAR BUMPER COMPONENTS



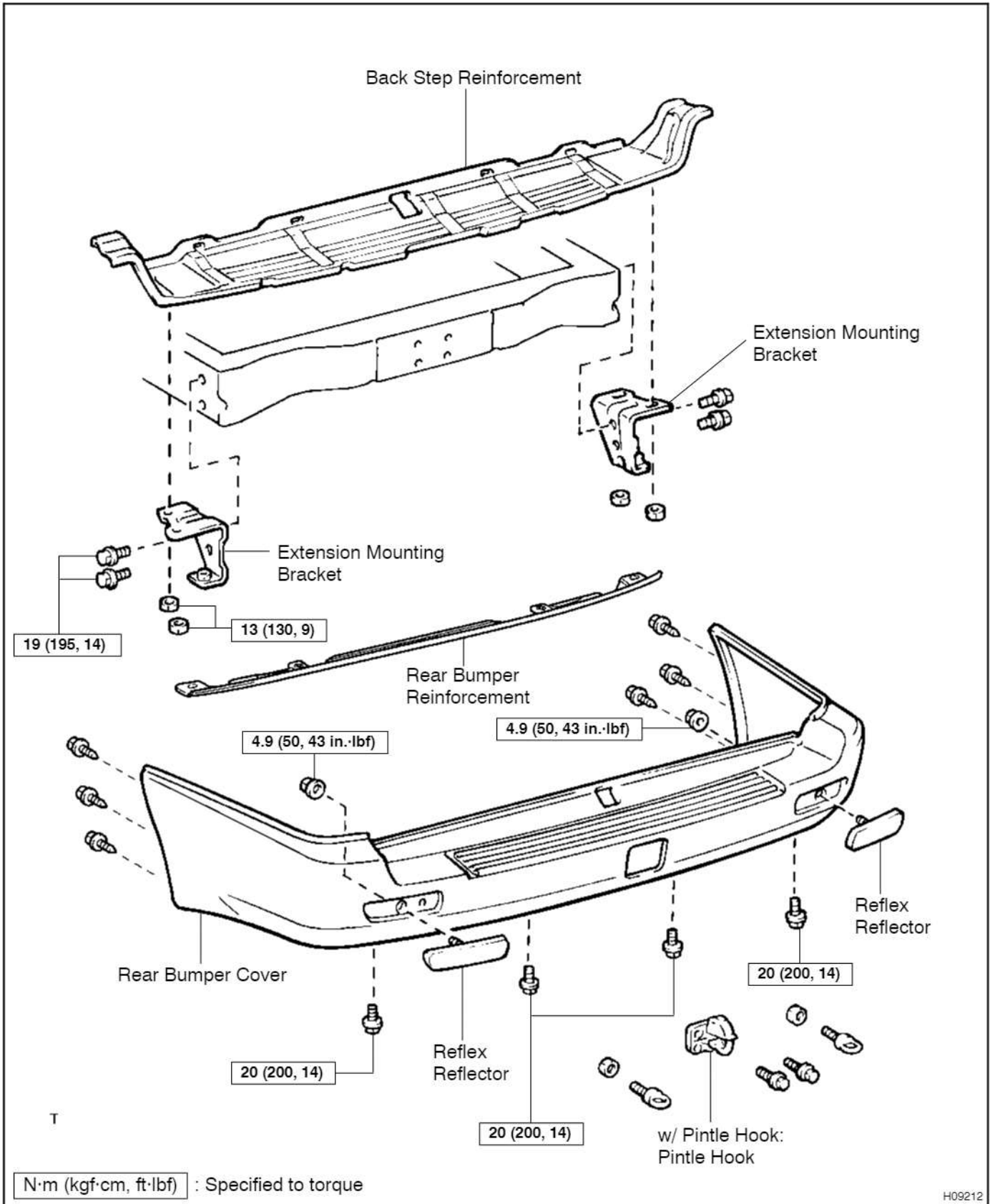





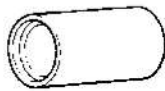

BO28A-01

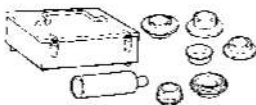





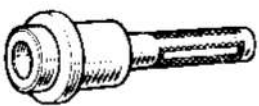
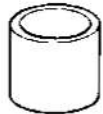

cardiagn.com

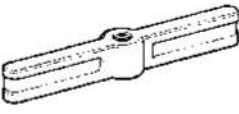
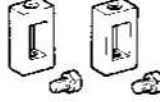
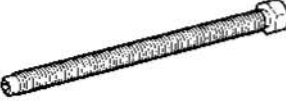

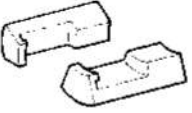
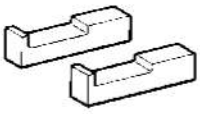
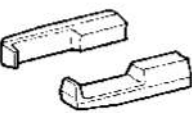

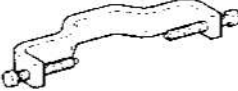
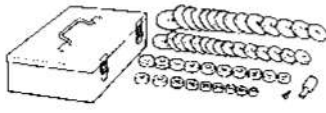

TRANSFER (Part-Time 4WD Type)**SST (Special Service Tools)**

PP21-01

	09309-60010	Extension Pipe	Front extension housing
	09316-20011	Transfer Bearing Replacer	Front extension housing Output shaft, Transfer assembly
	09316-60011	Transmission & Transfer Bearing Replacer	
	(09316-00011)	Replacer Pipe	Front extension housing Output shaft, Transfer assembly
	(09316-00031)	Replacer "B"	Front extension housing Transfer assembly
	(09316-00061)	Replacer "E"	Front extension housing
	(09316-00071)	Replacer "F"	Front extension housing
	09330-00021	Companion Flange Holding Tool	Transfer assembly
	09517-12010	Rear Axle Shaft Oil Seal Replacer	Transfer assembly
	09631-20081	Seal Ring Tool	Transfer assembly
	09649-17010	Steering Knuckle Tool	Front extension housing
	09950-00020	Bearing Remover	Output shaft

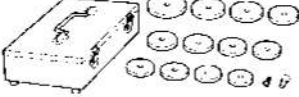

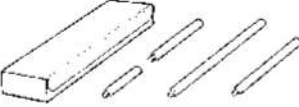
	09950-40011	Puller B Set	
	(09951-04020)	Hanger 200	Front extension housing Transfer assembly
	(09952-04010)	Slide Arm	Front extension housing Transfer assembly
	(09953-04030)	Center Bolt 200	Front extension housing Transfer assembly
	(09954-04010)	Arm 25	Front extension housing Transfer assembly
	(09955-04021)	Claw No.2	Front extension housing Transfer assembly
	(09955-04051)	Claw No.5	Front extension housing
	(09955-04061)	Claw No.6	Transfer assembly
	(09957-04010)	Attachment	Transfer assembly Front extension housing
	(09958-04011)	Holder	Transfer assembly
	09950-60010	Replacer Set	
	(09951-00270)	Replacer 27	Transfer assembly
	(09951-00290)	Replacer 29	Transfer assembly

PREPARATION - TRANSFER (Part-Time 4WD Type)

	<p>(09951-00320) Replacer 32</p>	<p>Transfer assembly</p>
	<p>(09951-00400) Replacer 40</p>	<p>Transfer assembly</p>
	<p>09950-60020 Replacer Set No.2</p>	
	<p>(09951-00790) Replacer 79</p>	<p>Transfer assembly</p>
	<p>(09951-00890) Replacer 89</p>	<p>Transfer assembly</p>
	<p>09950-70010 Handle Set</p>	
	<p>(09951-07150) Handle 150</p>	<p>Transfer assembly</p>

cardiagn.com

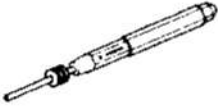
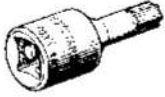
RECOMMENDED TOOLS

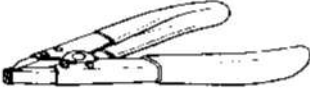
	09031-00030 Pin Punch .	
	09042-00020 Torx Socket T40 .	
	09082-00040 TOYOTA Electrical Tester.	
	09905-00012 Snap Ring No.1 Expander .	

EQUIPMENT

Dial indicator	
Torque wrench	
Magnetic finger	
Feeler gauge	
Vernier calipers	

cardiagn.com

SSM (Special Service Materials)

08826-00090	Seal Packing 1281, THREE BOND 1281 or equivalent (FIPG)	
08833-00080	Adhesive 1344 THREE BOND 1344 LOCTITE 242 or equivalent	

SUSPENSION AND AXLE

SST (Special Service Tools)

PP21E-01

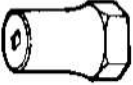
	09607-60020 Front Wheel Adjusting Nut Wrench	Front axle
---	--	------------

cardiagn.com

RECOMMENDED TOOLS

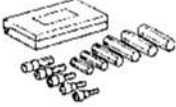
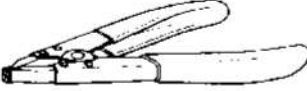
	09040-00010 Hexagon Wrench Set .	
	09905-00012 Snap Ring No.1 Expander .	

EQUIPMENT

Dial indicator with magnetic base	
Spring tension gauge	
Torque wrench	

AIR CONDITIONING RECOMMENDED TOOLS

PF21N-01

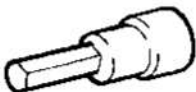
	(09043-20100) Socket Hexagon Wrench 10.	10.0mm (0.39 in.)
---	---	-------------------

EQUIPMENT

PF1AG-05

Torque wrench	
---------------	--

cardiagn.com

LUBRICANT

Item	Capacity	Classification
Compressor oil	-	ND-OIL 8 or equivalent

FRONT AXLE HUB (Rigid Front Suspension) COMPONENTS

SA1A4-02

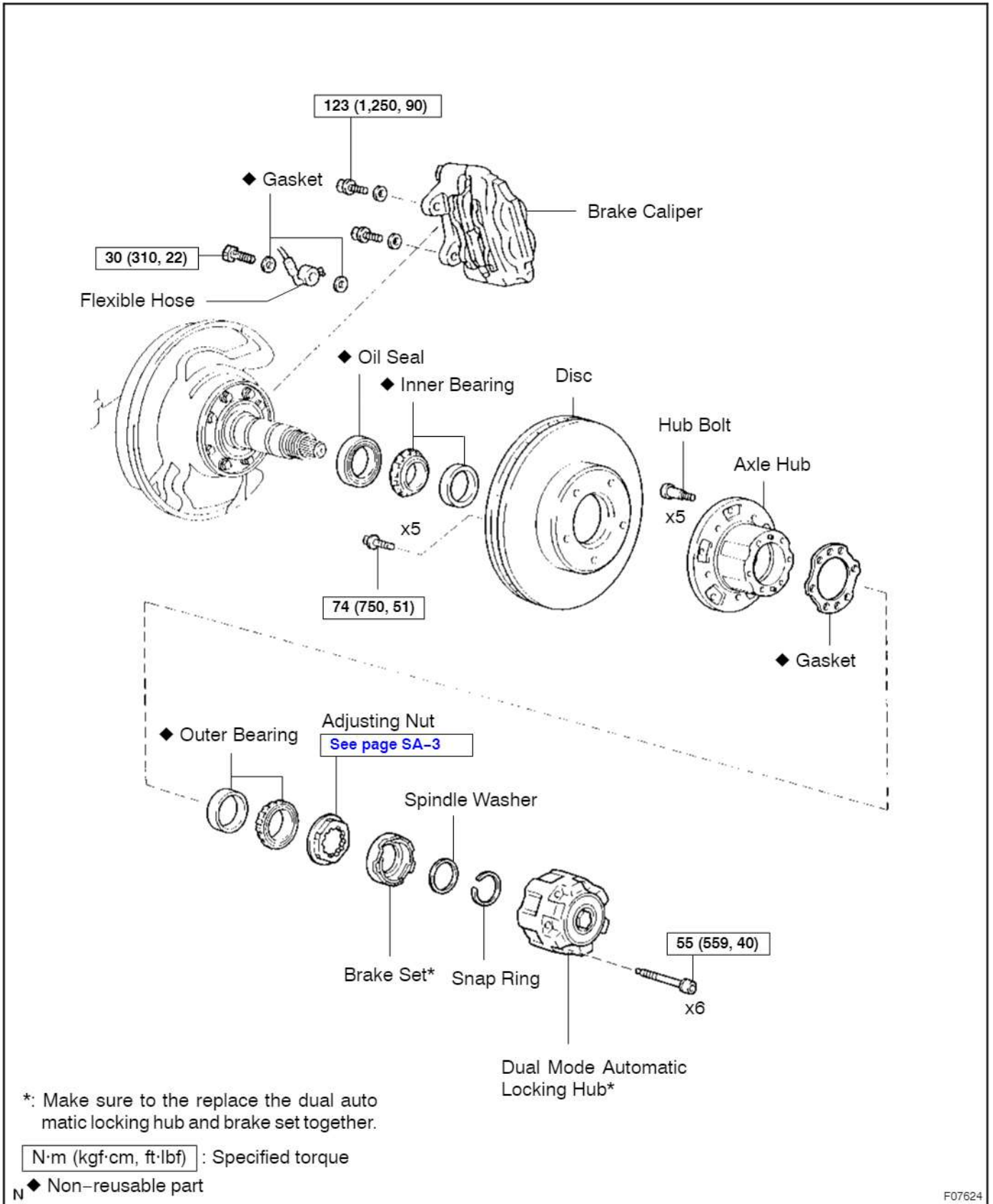

cardiagn.com

F07624

REMOVAL

1. REMOVE FRONT WHEEL
2. REMOVE BRAKE CALIPER
 - (a) Remove the bolt and 2 gaskets from the brake caliper and disconnect the flexible hose.

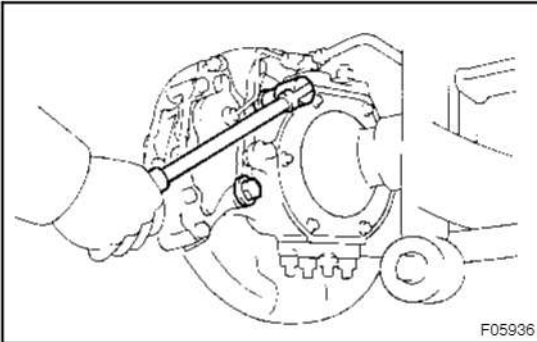

- (b) Remove the 2 bolts, washers and brake caliper from the steering knuckle.

3. REMOVE DUAL MODE AUTOMATIC LOCKING HUB
(See page SA-10)

4. REMOVE SNAP RING, SPINDLE WASHER AND BRAKE SET FROM SPINDLE

- (a) Using a snap ring expander, remove the snap ring.
 - (b) Remove the spindle washer and brake set.

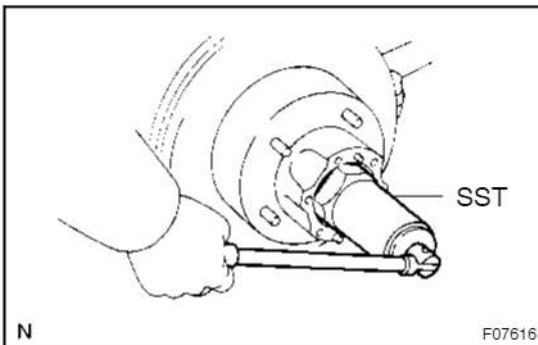

5. REMOVE AXLE HUB WITH DISC FROM SPINDLE

- (a) Using SST, remove the adjusting nut.
SST 09607-60020
 - (b) Remove the axle hub with disc together with the outer bearing.

INSTALLATION

1. INSTALL AXLE HUB WITH DISC TO SPINDLE

- (a) Place the axle hub with disc to the spindle.
- (b) Install the outer bearing.

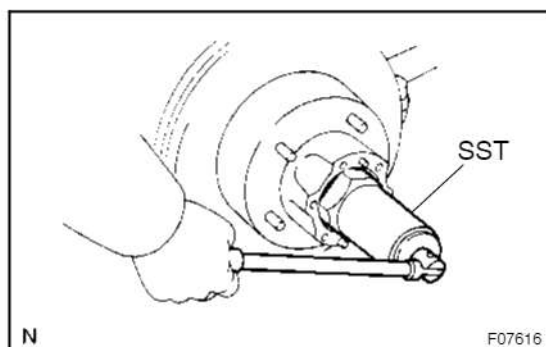

2. ADJUST PRELOAD

- (a) Install the adjusting nut and tighten it using SST.
SST 09607-60020

Torque: 59 N·m (600 kgf·cm, 43 ft·lbf)

- (b) Turn the hub right and left 2 or 3 times.
- (c) Loosen the nut until it can be turned by hand.
- (d) Using SST, retighten the adjusting nut.
SST 09607-60020

Torque: 49 N·m (500 kgf·cm, 36 ft·lbf)

- (e) Tighten the adjusting nut in the tightening direction so that the grooves of the adjusting nut are aligned with on the key grooves before and after spindle.

Torque: 49 - 79 N·m (500 - 800 kgf·cm, 36 - 58 ft·lbf)

NOTICE:

Check that the bearing has no play.

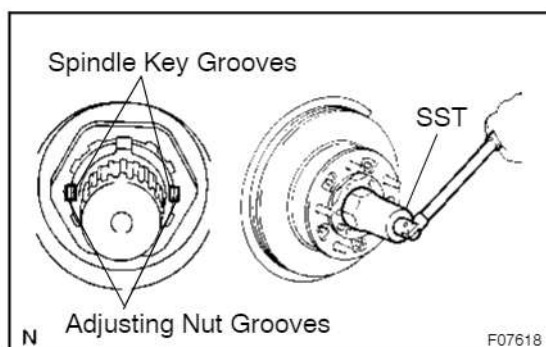

- (f) Using a spring tension gauge, measure the preload.

Preload (at starting):

42 - 67 N (4.3 - 6.8 kgf, 9.5 - 15.0 lbf)

HINT:

Make sure to check preload in the direction of rotation.

If the preload is not within the specified value, adjust it again with the adjusting nut.

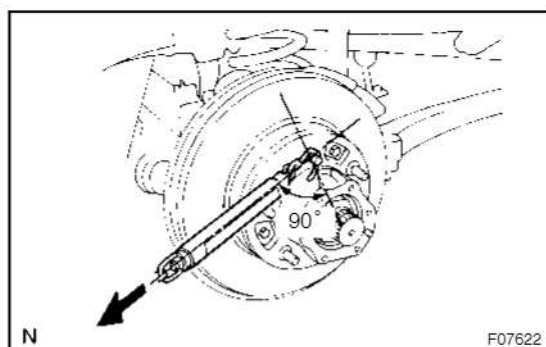

3. INSTALL BRAKE SET, SPINDLE WASHER AND SNAP RING TO SPINDLE

- (a) Check that the brake wire is within the range of 60° of the brake outer raised portion on the opposite side to the brake set mark.

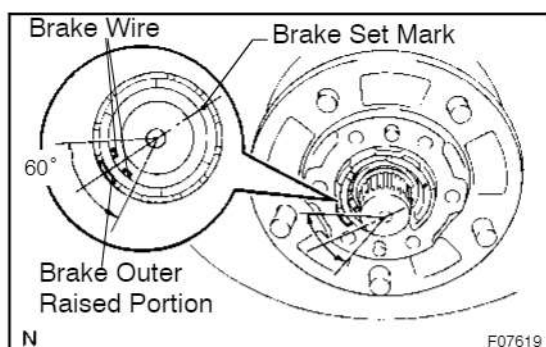

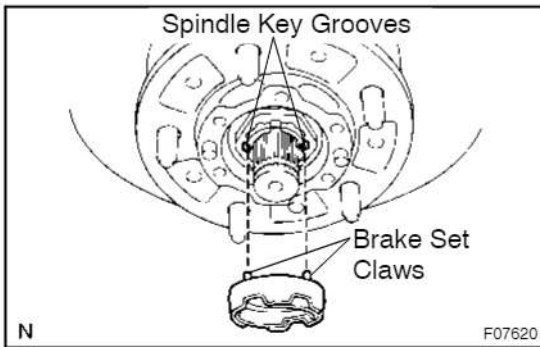

- (b) Align the claws of the brake set with the key grooves of the spindle and assemble the brake set.
- (c) Install the spindle washer and using a snap ring expander, install the snap ring.
- (d) Install the bolt to the axle shaft.

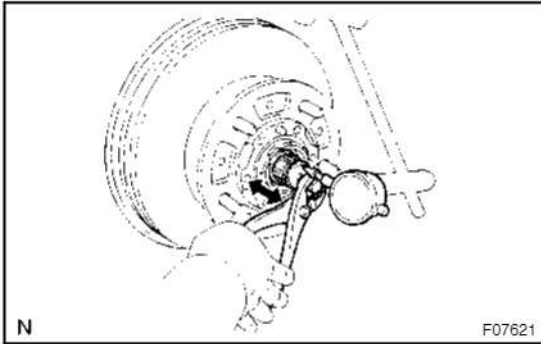

- (e) Using a dial indicator, check the backlash near the center of the axle shaft, while pulling the bolt with pliers.

Maximum: 0.2 mm (0.008 in.) or less

If the backlash is not within the specified value, replace the snap ring.

Snap ring thickness:

1.80 mm (0.0709 in.)	2.40 mm (0.0945 in.)
2.00 mm (0.0787 in.)	2.60 mm (0.1024 in.)
2.20 mm (0.0866 in.)	2.80 mm (0.1102 in.)

- (f) Remove the bolt from the axle shaft.
- 4. INSTALL DUAL MODE AUTOMATIC LOCKING HUB (See page SA-11)**
- 5. INSTALL BRAKE CALIPER**
 - (a) Install the brake caliper with the 2 bolts and washers to the steering knuckle.
Torque: 123 N·m (1,250 kgf·cm, 90 ft·lbf)
 - (b) Connect the flexible hose and install 2 new gaskets and bolt.
Torque: 30 N·m (310 kgf·cm, 22 ft·lbf)
- 6. INSTALL FRONT WHEEL**
Torque: 209 N·m (2,131 kgf·cm, 154 ft·lbf)
- 7. BLEED BRAKE LINE (See Pub. No. RM616E on page BR-5 or BR-10)**

FRONT AXLE HUB (Independent Front Suspension) COMPONENTS

SA149-05

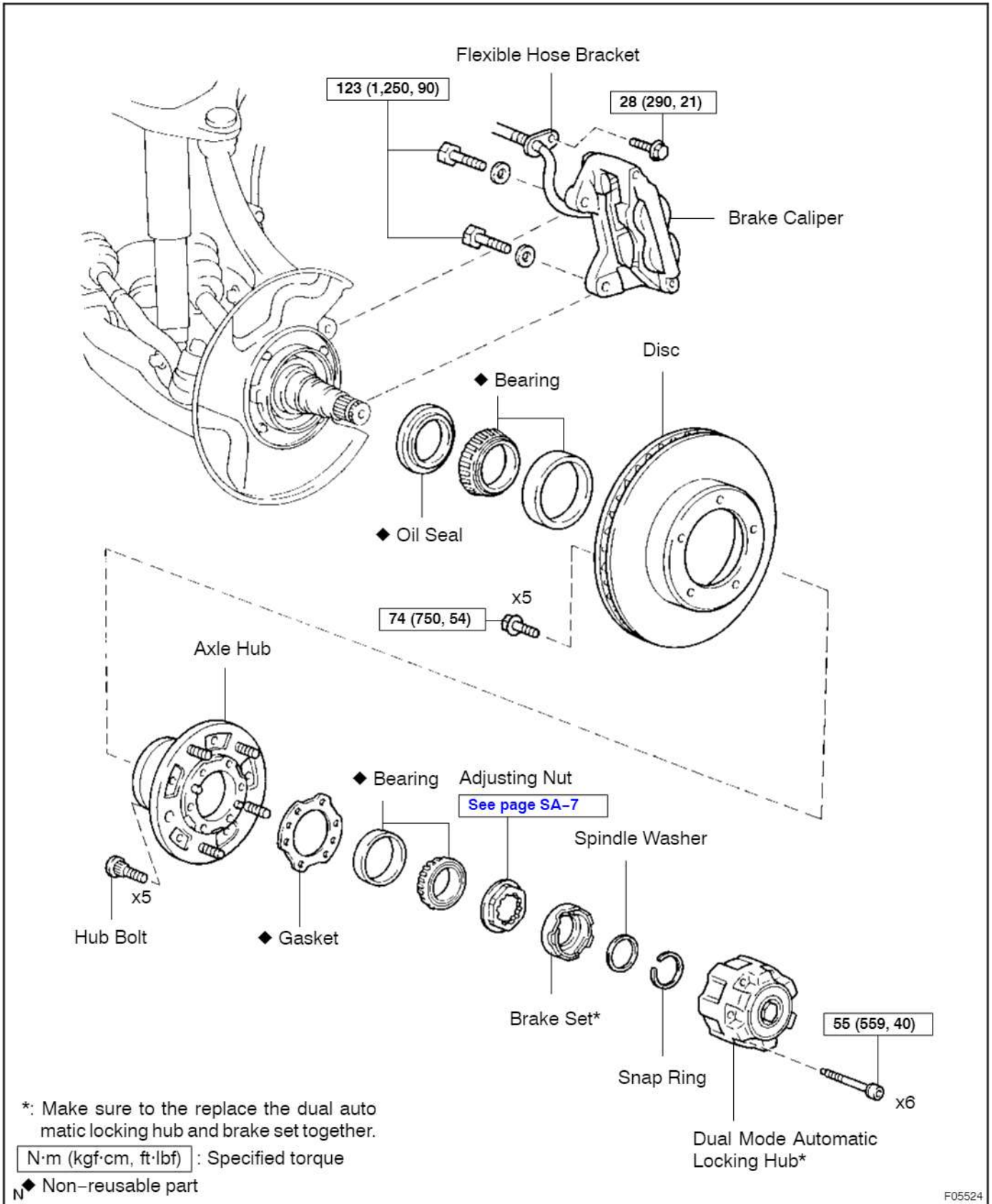

cardiagn.com

REMOVAL

1. REMOVE FRONT WHEEL

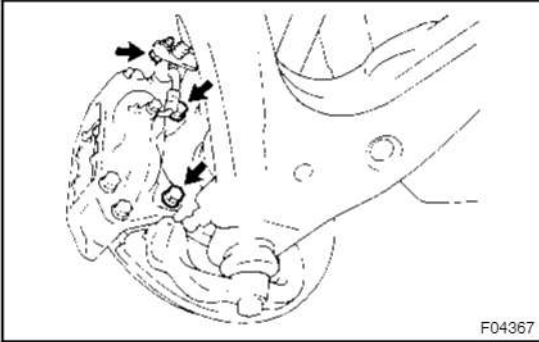

2. REMOVE BRAKE CALIPER

- (a) Remove the bolt and disconnect the flexible hose bracket from the steering knuckle.
- (b) Remove the 2 bolts, washers and brake caliper.
- (c) Support the brake caliper securely.

3. REMOVE DUAL MODE AUTOMATIC LOCKING HUB (See page SA-10)

4. REMOVE SNAP RING, SPINDLE WASHER AND BRAKE SET FROM STEERING KNUCKLE

- (a) Using a snap ring expander, remove the snap ring.
- (b) Remove the spindle washer and brake set.

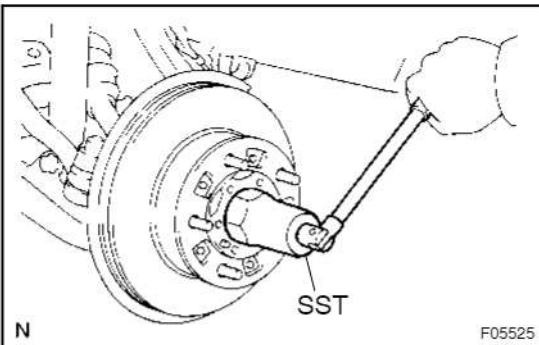

5. REMOVE AXLE HUB WITH DISC FROM STEERING KNUCKLE

- (a) Using SST, remove the adjusting nut.
SST 09607-60020
- (b) Remove the axle hub with disc together with the outer bearing.

NOTICE:

Be careful not to damage the ABS speed sensor rotor (w/ ABS) and oil seal.

INSTALLATION

1. INSTALL AXLE HUB TO STEERING KNUCKLE

- (a) Place the axle hub to the steering knuckle.

NOTICE:

Be careful not to damage the ABS speed sensor rotor (w/ ABS) and oil seal.

- (b) Install the outer bearing.

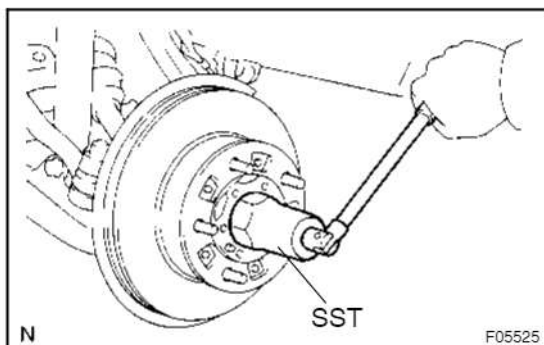

2. ADJUST PRELOAD

- (a) Install the adjusting nut and tighten it using SST.
SST 09607-60020

Torque: 59 N·m (600 kgf·cm, 43 ft·lbf)

- (b) Turn the hub right and left 2 or 3 times.
(c) Loosen the nut until it can be turned by hand.
(d) Using SST, retighten the adjusting nut.
SST 09607-60020

Torque: 49 N·m (500 kgf·cm, 36 ft·lbf)

- (e) Tighten the adjusting nut in the tightening direction so that the grooves of the adjusting nut are aligned with on the key grooves before and after spindle.

Torque: 49 - 79 N·m (500 - 800 kgf·cm, 36 - 58 ft·lbf)

NOTICE:

Check that the bearing has no play.

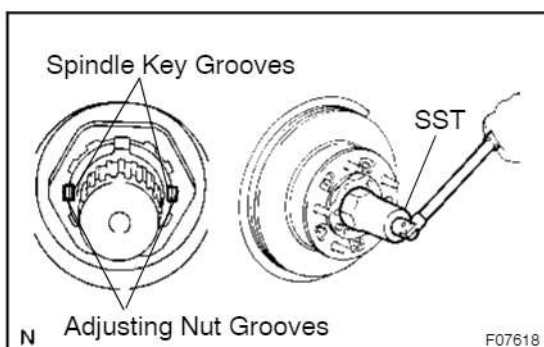

- (f) Using a spring tension gauge, measure the preload.

Preload (at starting):

42 - 67 N (4.3 - 6.8 kgf, 9.5 - 15.0 lbf)

HINT:

Make sure to check preload in the direction of rotation.

If the preload is not within the specified value, adjust it again with the adjusting nut.

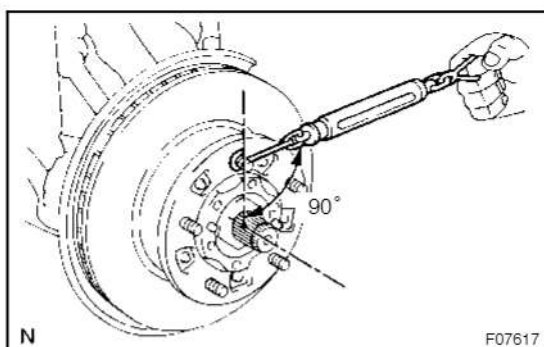

3. INSTALL BRAKE SET, SPINDLE WASHER AND SNAP RING TO STEERING KNUCKLE

- (a) Check that the brake wire is within the range of 60° of the brake outer raised portion on the opposite side to the brake set mark.

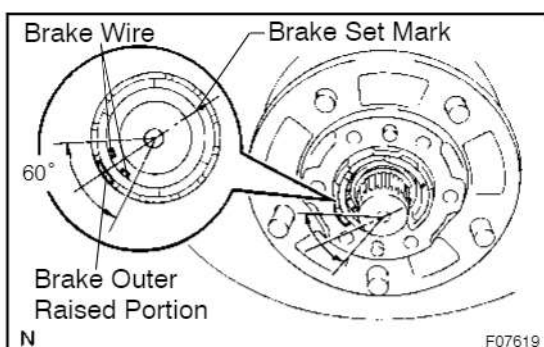

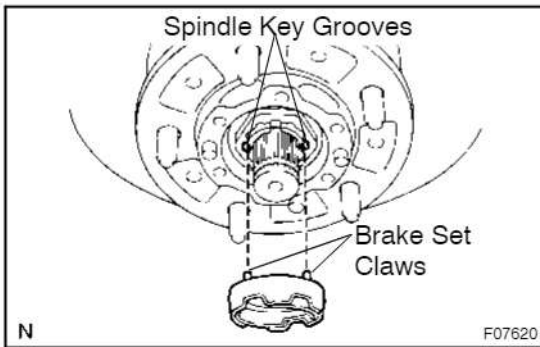

- (b) Align the claws of the brake set with the key grooves of the spindle and assemble the brake set.
- (c) Install the spindle washer and using a snap ring expander, install the snap ring.
- (d) Install the bolt to the drive shaft.

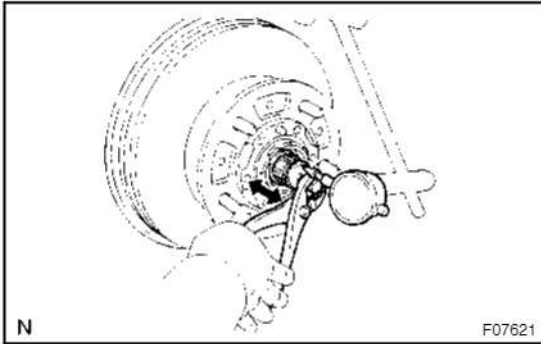

- (e) Using a dial indicator, check the backlash near the center of the drive shaft, while pulling the bolt with pliers.

Maximum: 0.2 mm (0.008 in.) or less

If the backlash is not within the specified value, replace the snap ring.

Snap ring thickness:

1.80 mm (0.0709 in.)	2.40 mm (0.0945 in.)
2.00 mm (0.0787 in.)	2.60 mm (0.1024 in.)
2.20 mm (0.0866 in.)	2.80 mm (0.1102 in.)

- (f) Remove the bolt from the drive shaft.
4. **INSTALL DUAL MODE AUTOMATIC LOCKING HUB**
(See page SA-11)
5. **INSTALL BRAKE CALIPER**
 - (a) Install the brake caliper with the 2 bolts and washers.
Torque: 123 N·m (1,250 kgf·cm, 90 ft·lbf)
 - (b) Connect the flexible hose bracket to the steering knuckle with the bolt.
Torque: 28 N·m (290 kgf·cm, 21 ft·lbf)
6. **INSTALL FRONT WHEEL**
Torque:
Steel wheel: 209 N·m (2,131 kgf·cm, 154 ft·lbf)
Aluminum wheel: 131 N·m (1,340 kgf·cm, 97 ft·lbf)
7. **w/ ABS:**
CHECK ABS SPEED SENSOR SIGNAL (See Pub. No. RM616E on page DI-312)

DUAL MODE AUTOMATIC LOCKING HUB (DALH) COMPONENTS

SA11J-01

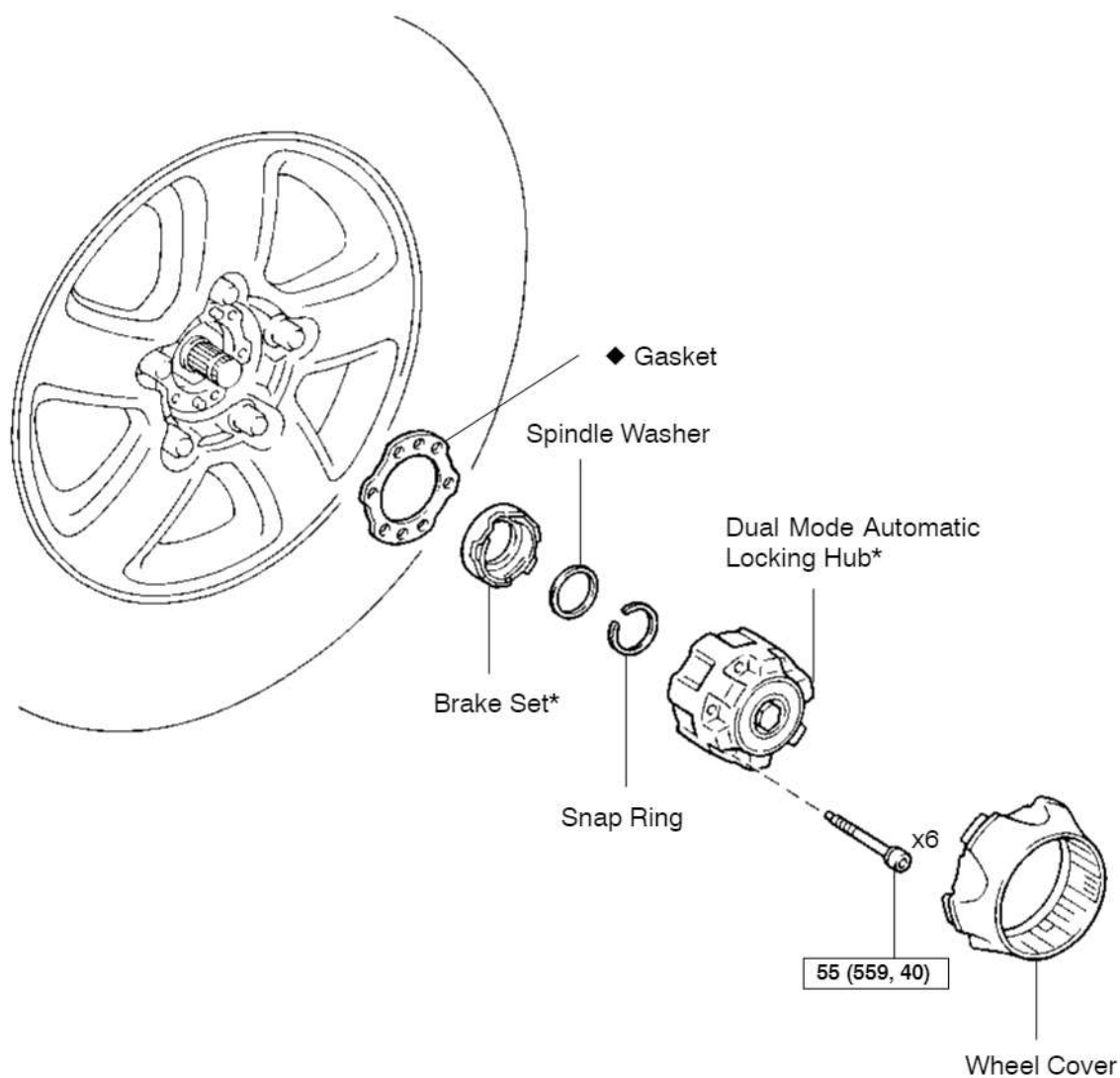

*: Make sure to the replace the dual auto matic locking hub and brake set together.

N·m (kgf·cm, ft·lbf) : Specified torque

◆ Non-reusable part

N

F05520

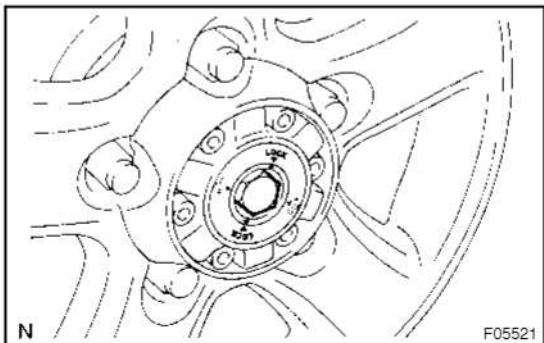

REMOVAL

1. SET KNOB OF DUAL MODE AUTOMATIC LOCKING HUB

Using a hub nut wrench, set the knob of the dual mode automatic locking hub to "LOCK" position.

2. REMOVE WHEEL COVER

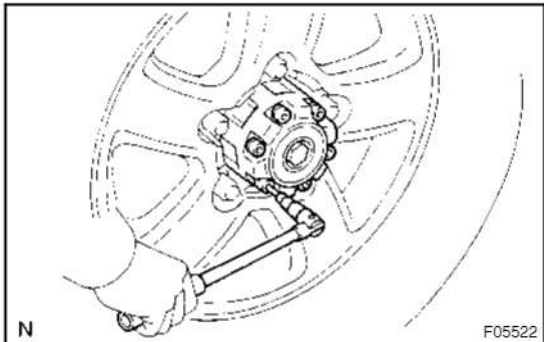

3. REMOVE DUAL MODE AUTOMATIC LOCKING HUB

Using a 8 mm hexagon wrench, remove the 6 hexagon bolts and locking hub.

4. REMOVE SNAP RING, SPINDLE WASHER AND BRAKE SET FORM SPINDLE (OR STEERING KNUCKLE)

- (a) Using a snap ring expander, remove the snap ring.
- (b) Remove the spindle washer and brake set.

5. REMOVE GASKET

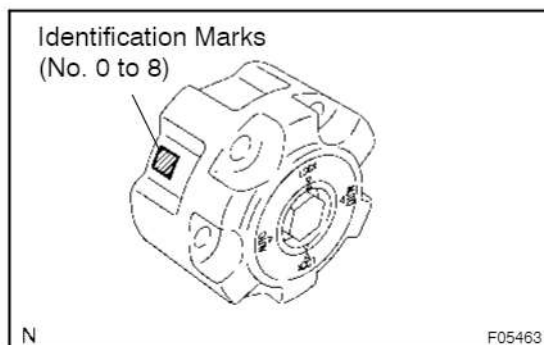

INSTALLATION

HINT:

- Replace the rocking hub assembly for right and left at the same time, while matching the identification marks (No. 0 to 8) on both rocking hubs.
- After assembling the dual automatic rocking hub to the axle hub, when the knob of the rocking hub is turned to "AUTO", the rocking hub might be either locked or free. Therefore, it is necessary to turn the axle hub to free. Also it is necessary to move the vehicle back and forth with 2WD to turn the rocking hub free.

1. INSTALL BRAKE SET, SPINDLE WASHER AND SNAP RING TO SPINDLE (OR STEERING KNUCKLE)

RFS: (See page SA-3)

IFS: (See page SA-7)

2. INSTALL NEW GASKET

3. CHECK KNOB OF DUAL MODE AUTOMATIC LOCKING HUB IN "LOCK" POSITION

4. INSTALL DUAL MODE AUTOMATIC LOCKING HUB

- (a) Align the marks on the brake set and notch on the locking hub.

HINT:

Check that the brake wire of the brake set does not touch the claw on the release plate of the rocking hub.

- (b) Insert the gear drive of the locking hub into the drive shaft (or axle shaft) and push the locking hub into the axle hub.

HINT:

While holding the rocking hub to the axle hub, ensure that there is no gap between the axle hub and rocking hub.

If there is a gap, the brake wire and claw of the release plate might touch. Check and repair it and confirm that there is no gap.

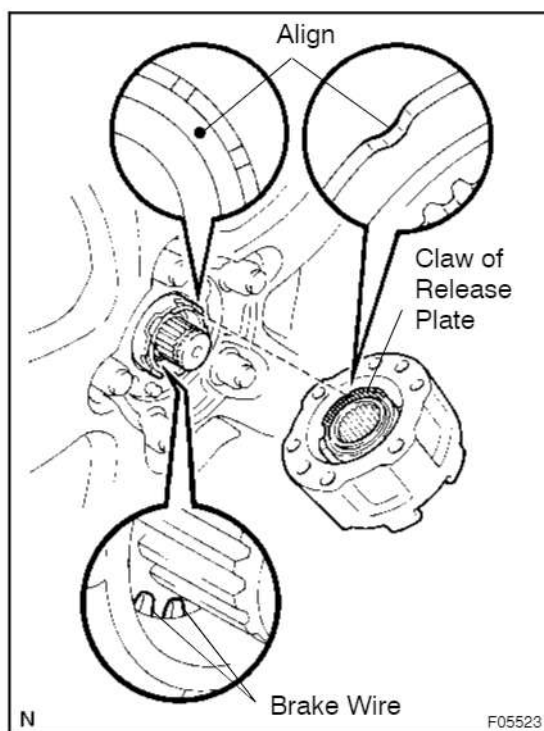

- (c) Using a 8 mm hexagon wrench, install the 6 hexagon bolts.

Torque: 55 N·m (559 kgf·cm, 40 ft·lbf)



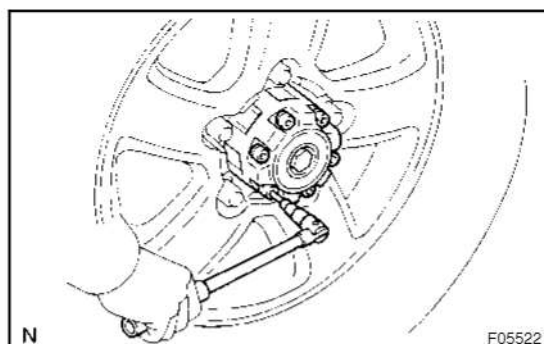







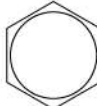

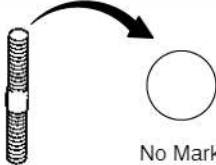
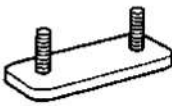

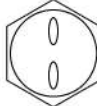











5. INSTALL WHEEL COVER



STANDARD BOLT

HOW TO DETERMINE BOLT STRENGTH

SS028-01

Bolt Type				Class
Hexagon Head Bolt		Stud Bolt	Weld Bolt	
Normal Recess Bolt	Deep Recess Bolt			
  No Mark	 No Mark	 No Mark		4T
 				5T
  w/ Washer	 w/ Washer			6T
 	 			7T
		 		8T
				9T
	 			10T
	 			11T

cardiagn.com







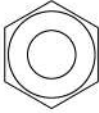
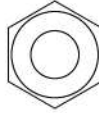
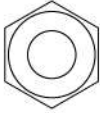

B06431

SPECIFIED TORQUE FOR STANDARD BOLTS

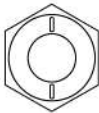
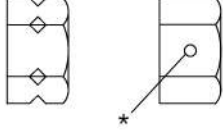
Class	Diameter mm	Pitch mm	Specified torque					
			Hexagon head bolt			Hexagon flange bolt		
			N·m	kgf·cm	ft·lbf	N·m	kgf·cm	ft·lbf
4T	6	1	5	55	48 in·lbf	6	60	52 in·lbf
	8	1.25	12.5	130	9	14	145	10
	10	1.25	26	260	19	29	290	21
	12	1.25	47	480	35	53	540	39
	14	1.5	74	760	55	84	850	61
	16	1.5	115	1,150	83	–	–	–
5T	6	1	6.5	65	56 in·lbf	7.5	75	65 in·lbf
	8	1.25	15.5	160	12	17.5	175	13
	10	1.25	32	330	24	36	360	26
	12	1.25	59	600	43	65	670	48
	14	1.5	91	930	67	100	1,050	76
	16	1.5	140	1,400	101	–	–	–
6T	6	1	8	80	69 in·lbf	9	90	78 in·lbf
	8	1.25	19	195	14	21	210	15
	10	1.25	39	400	29	44	440	32
	12	1.25	71	730	53	80	810	59
	14	1.5	110	1,100	80	125	1,250	90
	16	1.5	170	1,750	127	–	–	–
7T	6	1	10.5	110	8	12	120	9
	8	1.25	25	260	19	28	290	21
	10	1.25	52	530	38	58	590	43
	12	1.25	95	970	70	105	1,050	76
	14	1.5	145	1,500	108	165	1,700	123
	16	1.5	230	2,300	166	–	–	–
8T	8	1.25	29	300	22	33	330	24
	10	1.25	61	620	45	68	690	50
	12	1.25	110	1,100	80	120	1,250	90
9T	8	1.25	34	340	25	37	380	27
	10	1.25	70	710	51	78	790	57
	12	1.25	125	1,300	94	140	1,450	105
10T	8	1.25	38	390	28	42	430	31
	10	1.25	78	800	58	88	890	64
	12	1.25	140	1,450	105	155	1,600	116
11T	8	1.25	42	430	31	47	480	35
	10	1.25	87	890	64	97	990	72
	12	1.25	155	1,600	116	175	1,800	130

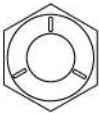
cardiagn.com

HOW TO DETERMINE NUT STRENGTH

Present Standard Hexagon Nut	Nut Type		Class
	Old Standard Hexagon Nut		
	Cold Forging Nut	Cutting Processed Nut	
 No Mark			4N
 No Mark (w/ Washer)	 No Mark (w/ Washer)	 No Mark	5N (4T)
 6N			6N
	 7N	 7N	7N (5T)
 8N			8N
 10N	 10N	 No Mark	10N (7T)
 11N			11N
 12N			12N

*: Nut with 1 or more marks on one side surface of the nut.

HINT:

Use the nut with the same number of the nut strength classification or the greater than the bolt strength classification number when tightening parts with a bolt and nut.

Example: Bolt = 4T

Nut = 4N or more

LAND CRUISER SUP (RM695E)

TRANSFER (Part-Time 4WD Type)

SS122-01

SERVICE DATA

Idler gear rear bearing adjusting shim thickness	Mark 2	0.30 mm (0.0118 in.)
	Mark 3	0.45 mm (0.0177 in.)
	Mark 4	2.40 mm (0.0945 in.)
	Mark 5	2.60 mm (0.1024 in.)
	Mark 6	2.80 mm (0.1102 in.)
	Mark 7	3.00 mm (0.1181 in.)
	Mark 8	3.20 mm (0.1260 in.)
	Mark 9	3.40 mm (0.1339 in.)
	Mark 10	3.60 mm (0.1417 in.)
	Mark 11	3.80 mm (0.1496 in.)
	Mark 12	4.00 mm (0.1575 in.)
	Mark 13	0.55 mm (0.0216 in.)
	Output shaft rear bearing adjusting shim thickness	Mark 2
Mark 3		0.45 mm (0.0177 in.)
Mark 4		1.00 mm (0.0394 in.)
Mark 5		1.20 mm (0.0472 in.)
Mark 6		1.40 mm (0.0551 in.)
Mark 7		1.60 mm (0.0630 in.)
Mark 8		1.80 mm (0.0709 in.)
Mark 9		2.00 mm (0.0787 in.)
Mark 10		2.20 mm (0.0866 in.)
Mark 11		2.40 mm (0.0945 in.)
Mark 12		2.60 mm (0.1024 in.)
Mark 13		0.55 mm (0.0216 in.)
High speed gear thrust clearance		STD
	Max.	0.43 mm (0.0169 in.)
Low speed gear thrust clearance	STD	0.20 - 0.45 mm (0.0079 - 0.0177 in.)
	Max.	0.45 mm (0.0177 in.)
High speed gear and low speed gear radial clearance	STD	0.015 - 0.068 mm (0.0005 - 0.0027 in.)
	Max.	0.068 mm (0.0027 in.)
Synchronizer ring to gear clearance	STD	1.02 - 1.98 mm (0.0402 - 0.0780 in.)
	Min.	1.02 mm (0.0402 in.)
Shift fork to hub sleeve clearance	STD	0.1 - 0.4 mm (0.0039 - 0.0157 in.)
	Max.	0.4 mm (0.0157 in.)
Output shaft clutch hub snap ring thickness	Mark A	2.60 mm (0.1024 in.)
	Mark B	2.65 mm (0.1043 in.)
	Mark C	2.70 mm (0.1063 in.)
	Mark D	2.75 mm (0.1083 in.)
	Mark E	2.80 mm (0.1102 in.)
	Mark F	2.85 mm (0.1122 in.)
	Mark G	2.90 mm (0.1142 in.)
Output shaft front drive gear piece snap ring thickness	Mark A	2.00 mm (0.0787 in.)
	Mark B	2.10 mm (0.0827 in.)
	Mark C	2.20 mm (0.0866 in.)
	Mark D	2.30 mm (0.0906 in.)
	Mark E	2.40 mm (0.0945 in.)

cardiagn.com

SERVICE SPECIFICATIONS - TRANSFER (Part-Time 4WD Type)

Front extension housing ball bearing snap ring thickness	Mark A	1.70 mm (0.0669 in.)
	Mark B	1.80 mm (0.0709 in.)
Front output shaft drive clutch hub snap ring thickness	Mark A	2.00 mm (0.0787 in.)
	Mark B	2.10 mm (0.0827 in.)
	Mark C	2.20 mm (0.0866 in.)
	Mark D	2.30 mm (0.0906 in.)
	Mark E	2.40 mm (0.0945 in.)

TORQUE SPECIFICATION

Part tightened		N·m	kgf·cm	ft·lbf
Drain and filler plug		37	380	27
Lever lock pin		12	120	9
Oil receiver x Front case		12	120	9
Case cover x Rear case		37	380	27
Rear extension housing x Rear case		37	380	27
Front extension housing x Front case		37	380	27
Transfer 4WD position switch		37	380	27
L4 position switch		37	380	27
Neutral position switch		37	380	27
Screw plug		19	190	14
Output shaft lock nut		127	1,300	94
Speed sensor driven gear set bolt		11	115	8
Oil receiver pipe x Rear case	Bolt A	12	120	9
(See page TR-3)	Bolt B	18	185	13
Front case x Rear case		37	380	27
Oil receiver pipe x Front extension housing		4.9	50	43 in·lbf

SUSPENSION AND AXLE

SERVICE DATA

SS120-01

Front axle	Wheel bearing preload (at starting)	42 – 67 N (4.3 – 6.8 kgf, 9.5 – 15.0 lbf)
	Front axle backlash	Maximum 0.2 mm (0.008 in.)
	Front axle snap ring thickness	1.80 mm (0.0709 in.) 2.00 mm (0.0787 in.) 2.20 mm (0.0866 in.) 2.40 mm (0.0945 in.) 2.60 mm (0.1024 in.) 2.80 mm (0.1102 in.)

TORQUE SPECIFICATION

Part tightened	N·m	kgf·cm	ft·lbf	
FRONT AXLE HUB (RFS)				
Hub nut	209	2,131	154	
Steering knuckle x Brake caliper	123	1,250	90	
Flexible hose x Brake caliper	30	310	22	
Axle hub bearing adjusting nut	See page SA-3			
FRONT AXLE HUB (IFS)				
Hub nut	Steel wheel	209	2,131	154
	Aluminum wheel	131	1,340	97
Steering knuckle x Brake caliper	123	1,250	90	
Flexible hose bracket x Steering knuckle	28	290	21	
Axle hub bearing adjusting nut	See page SA-3			
DUAL MODE AUTOMATIC LOCKING HUB				
Dual mode automatic locking hub x Axle hub	55	559	40	

BODY**TORQUE SPECIFICATION**

SS022-02

Part tightened		N·m	kgf·cm	ft·lbf
FRONT BUMPER		-	-	-
Front bumper cover x Body	Bolt:	8.3	85	74 in.·lbf
Front bumper cover x Body	Screw:	2.9	30	26 in.·lbf
Fog light x Front bumper cover		4.9	50	43 in.·lbf
Winch roller bracket x Front base member	Upper Side:	22	220	16
Winch roller bracket x Front base member	Lower Side:	28	290	21
Front bumper reinforcement x Front base member		28	290	21
Front base member x Winch assembly		22	220	16
Front base member x Body		99	1,010	73
Winch base bracket x Winch assembly		16	160	12
REAR BUMPER		-	-	-
Rear bumper cover x Body		20	200	14
Reflex reflector x Rear bumper cover		4.9	50	43 in.·lbf
Rear bumper reinforcement x Extension mounting bracket		13	130	9
Extension mounting bracket x Body		19	195	14
FRONT SEAT (Bench Type)		-	-	-
Rear seat track retainer x Seat Adjuster		20	200	14
Reclining connecting pipe x Seat adjuster		21	210	15
Seat cushion assembly x Seat adjuster	A Bolt:	20	200	14
Seat cushion assembly x Seat adjuster	B Bolt:	21	210	15
Seatback assembly x Outer seat adjuster		43	440	32
Seatback assembly x Reclining adjuster		43	440	32
Center armrest x Seatback assembly		37	380	27
Center armrest hinge x Center armrest		37	380	27
Center armrest hinge x Seatback assembly		37	380	27
Front seat adjuster x Body		37	375	27

AIR CONDITIONING

TORQUE SPECIFICATION

SS004-03

Part tightened	N·m	kgf·cm	ft·lbf
REFRIGERANT LINE			
Liquid line (Nut)	14	140	10
Liquid line (Bolt)	10	100	7
Discharge line (Nut)	22	225	16
Discharge line (Bolt)	10	100	7
Cap	12.3	125	9

TROUBLESHOOTING

PROBLEM SYMPTOMS TABLE

TROSW-01

Use the table below to help you find the cause of the problem. The numbers indicate the priority of the likely cause of the problem. Check each part in order. If necessary, replace these parts.

Symptom	Suspect Area	See page
Noise	<ol style="list-style-type: none"> 1. Oil (Level low) 2. Oil (Wrong) 3. Gear (Worn or damaged) 4. Bearing (Worn or damaged) 	* * TR-2 TR-2
Oil leakage	<ol style="list-style-type: none"> 1. Oil (Level too high) 2. Gasket (Damaged) 3. Oil seal (Worn or damaged) 4. O-Ring (Worn or damaged) 	* * TR-2 TR-2
Hard to shift or will not shift	<ol style="list-style-type: none"> 1. Transfer shift lever assembly (Faulty) 2. w/ One touch 2-4 selector system (Faulty) 3. Synchronizer ring (Worn or damaged) 4. Shift key spring (Damaged) 	* * TR-2 TR-20 TR-20 TR-25
Jumps out of gear	<ol style="list-style-type: none"> 1. Locket ball spring (Damaged) 2. Shift fork (Worn) 3. Gear (Worn or damaged) 4. Bearing (Worn or damaged) 	TR-2 TR-2 TR-2 TR-2

*: See Pub. No. RM616E

DISASSEMBLY

1. REMOVE BREATHER HOSE
2. REMOVE SPEED SENSOR DRIVEN GEAR

Remove the bolt and speed sensor driven gear.

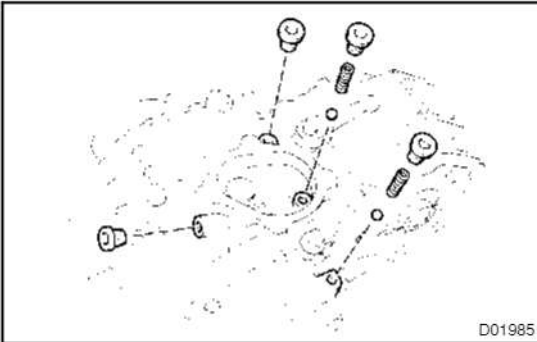

D01985

3. REMOVE SCREW PLUG, SPRING AND BALL

- (a) Using a torx socket wrench (T40), remove the 4 screw plugs.
- (b) Using a magnetic finger, remove the 2 springs and balls.

4. REMOVE TRANSFER INDICATOR SWITCH

Remove the transfer 4WD position switch, L4 position switch, neutral position switch and 3 gaskets.

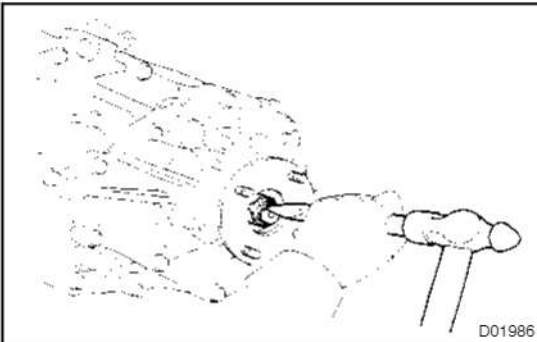

D01986

5. REMOVE OUTPUT SHAFT COMPANION FLANGE

- (a) Using a chisel and hammer, unstick the staked part of the nut.

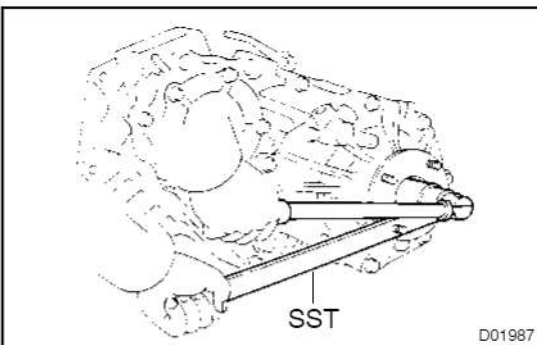

D01987

- (b) Using SST to hold the flange, remove the nut and O-ring.
SST 09330-00021
- (c) Remove the companion flange.

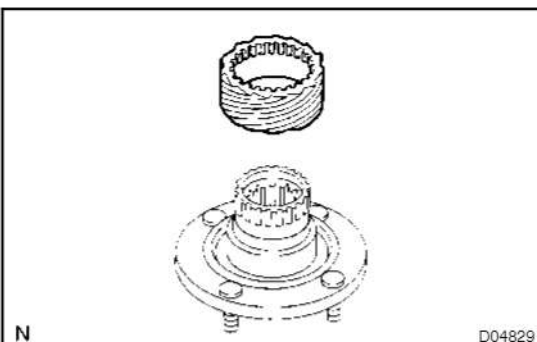

D04829

- (d) Remove the speed sensor drive gear from the companion flange.

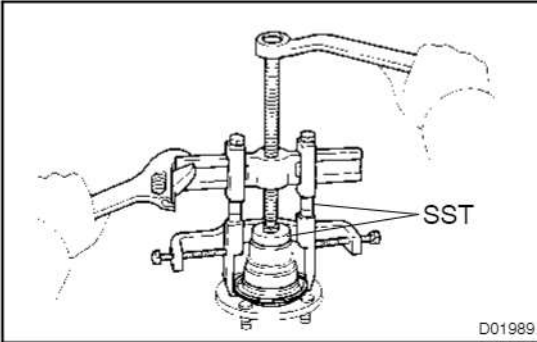

- (e) Using SST, remove the dust deflector from the companion flange.

SST 09950-40011 (09951-04020, 09952-04010, 09953-04030, 09954-04010, 09955-04061, 09957-04010, 09958-04011), 09950-60010 (09951-00400)

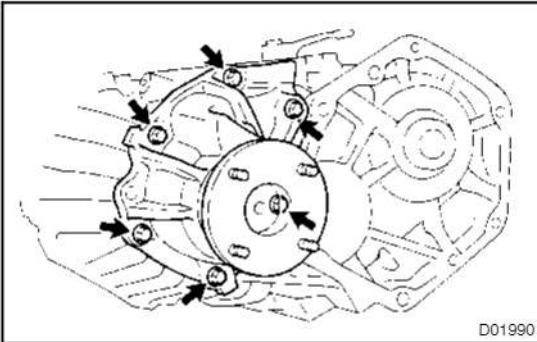

6. REMOVE FRONT EXTENSION HOUSING

Remove the 6 bolts and front extension housing.

HINT:

If necessary, tap the front extension housing lightly with a plastic hammer.

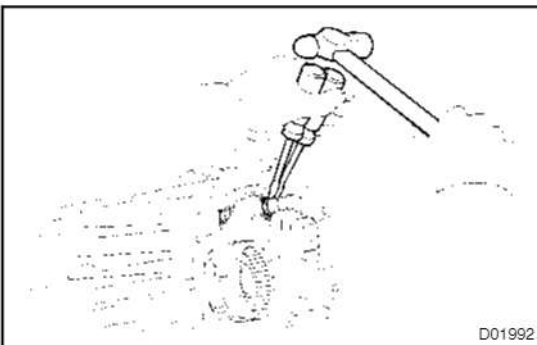

7. REMOVE FRONT DRIVE CLUTCH SLEEVE AND NO. 2 SHIFT FORK

- (a) Using 2 screwdrivers and a hammer, tap out the snap ring from the front drive shift fork shaft.

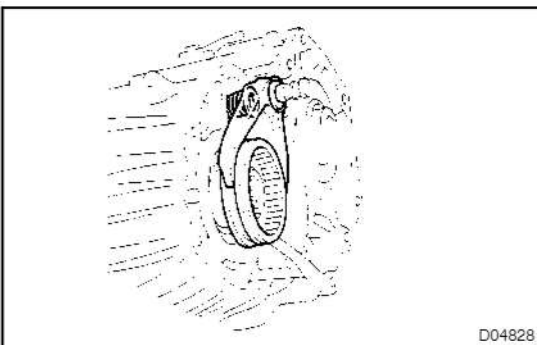

- (b) Remove the front drive clutch sleeve, No. 2 shift fork, 2 plate washers and compression spring.

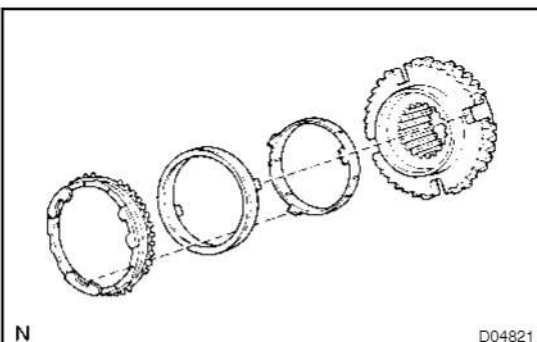

8. REMOVE NO. 2 SYNCHRONIZER OUTER RING, NO. 2 SYNCHRONIZER MIDDLE RING AND NO. 2 SYNCHRONIZER INNER RING

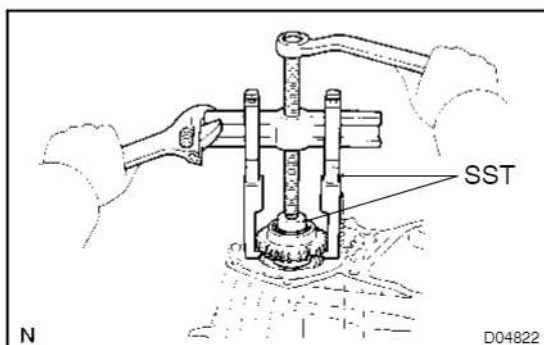
**9. REMOVE FRONT DRIVE GEAR PIECE**

- (a) Using a snap ring expander, remove the snap ring.
- (b) Using SST, remove the front drive gear piece.

SST 09950-40011 (09951-04020, 09952-04010, 09953-04030, 09954-04010, 09955-04021), 09950-60010 (09951-00290)

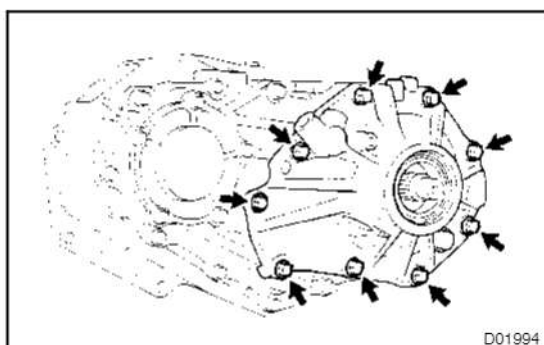
**10. REMOVE REAR EXTENSION HOUSING**

Remove the 9 bolts and rear extension housing.

HINT:

If necessary, tap the rear extension housing lightly with a plastic hammer.

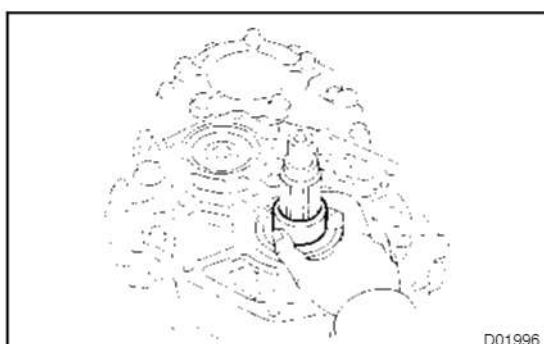
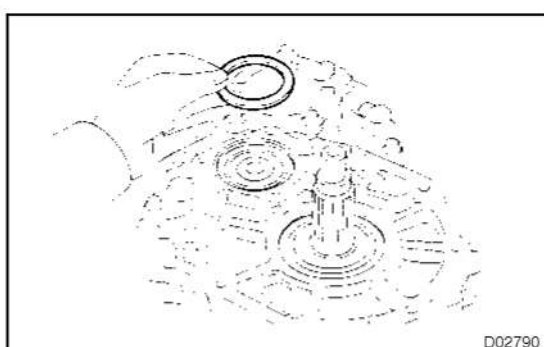
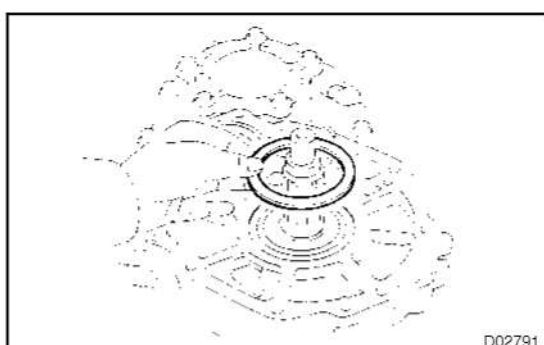
**11. REMOVE SPACER FROM OUTPUT SHAFT****12. REMOVE ADJUSTING SHIM FOR IDLER GEAR TAPER ROLLER BEARING****13. REMOVE ADJUSTING SHIM FOR OUTPUT SHAFT TAPER ROLLER BEARING**

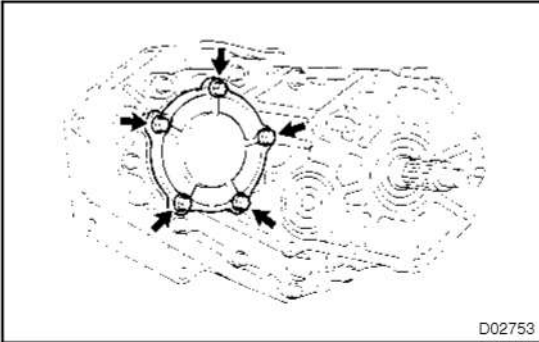
**14. REMOVE CASE COVER**

- (a) Remove the 5 bolts.
- (b) Using a brass bar and hammer, tap the case cover and remove it.

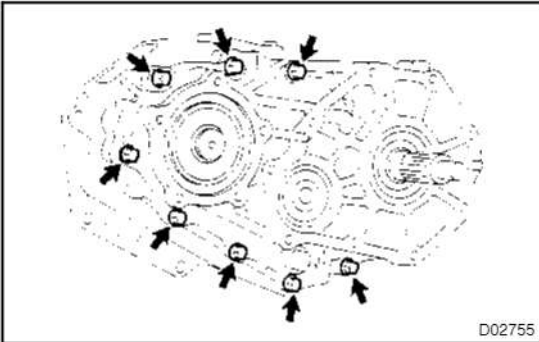
**15. SEPARATE FRONT CASE AND REAR CASE**

- (a) Using a snap ring expander, remove the snap ring of the input shaft.
- (b) Remove the 8 bolts.
- (c) Using a brass bar and hammer, tap the rear case and separate it.

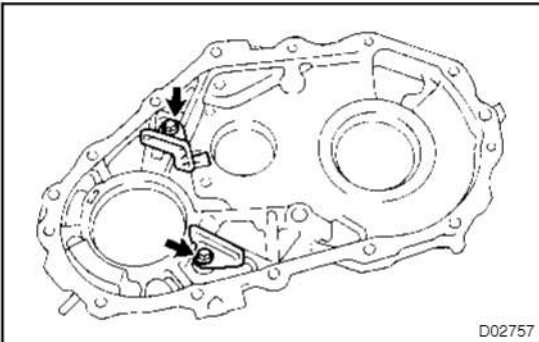
**17. REMOVE OIL RECEIVER PIPE**

Remove the 2 bolts and oil receiver pipes from the rear case.

18. REMOVE INPUT SHAFT ASSEMBLY FROM FRONT CASE**19. REMOVE IDLER GEAR ASSEMBLY FROM FRONT CASE****HINT:**

If it is difficult to remove the idler gear assembly, pull up the output shaft assembly.

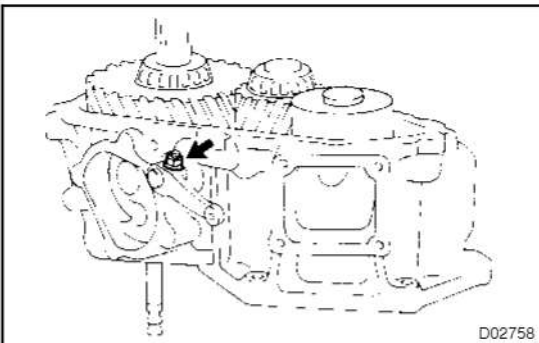
**20. REMOVE SHIFT OUTER LEVER**

- (a) Remove the nut and washer from the shift outer lever.

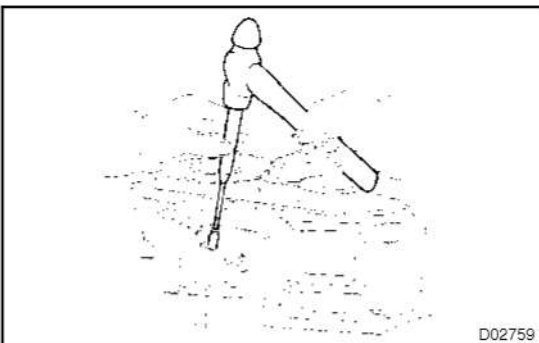

- (b) Using a pin punch and hammer, drive out the lever lock pin.
- (c) Remove the shift outer lever from the shift inner lever.

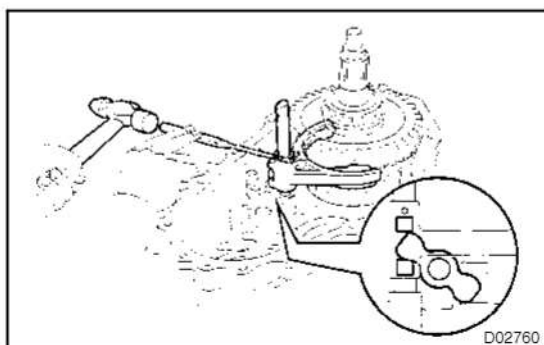

21. REMOVE NO. 1 SHIFT FORK AND HIGH AND LOW SHIFT FORK SHAFT

- (a) Using a pin punch and hammer, drive out the slotted spring pin from the No. 1 shift fork.
- (b) Remove the No. 1 shift fork and the high and low shift fork shaft.

22. REMOVE OUTPUT SHAFT ASSEMBLY FROM FRONT CASE

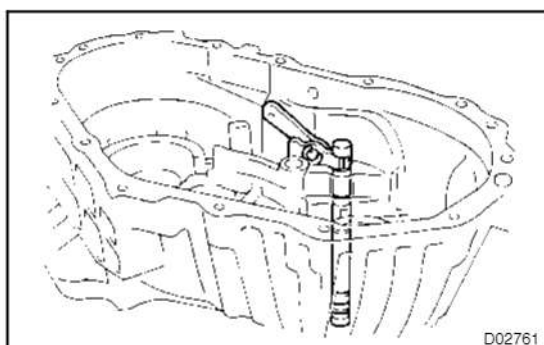

23. REMOVE FRONT DRIVE SHIFT FORK SHAFT

- (a) Remove the front drive shift fork shaft from the front case.

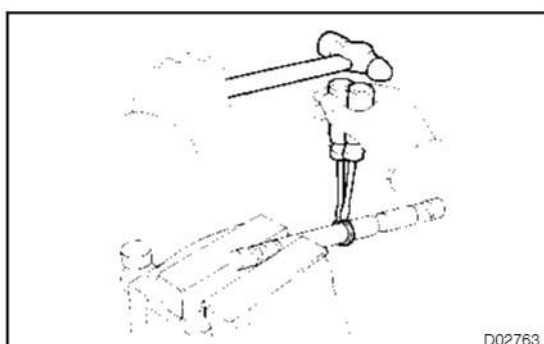

- (b) Using 2 screwdrivers and a hammer, drive out the snap ring from the front drive shift fork shaft.

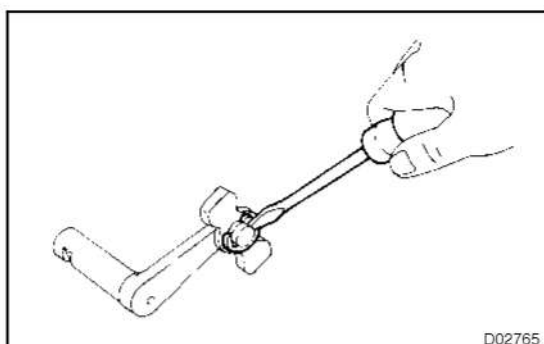

24. REMOVE SHIFT INNER LEVER SHAFT AND SHIFT INNER LEVER

- (a) Remove the shift inner lever shaft and shift inner lever from the front case.
- (b) Using a screwdriver, pry out the E-ring and separate the shift inner lever shaft and shift inner lever.

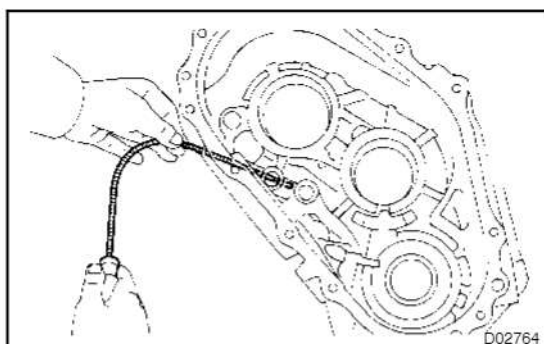

25. REMOVE STRAIGHT PIN

- Using a magnetic finger, remove the straight pin from the front case.

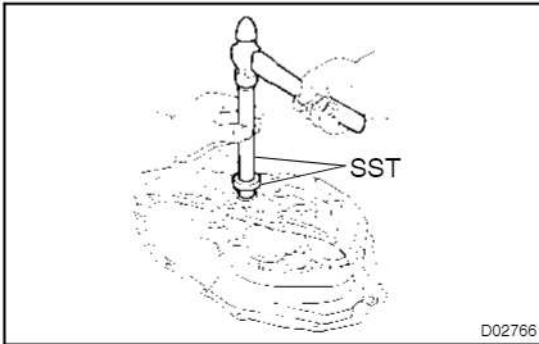

26. IF NECESSARY, REPLACE SHIFT LEVER OIL SEAL OF FRONT CASE

- (a) Using a screwdriver, pry out the oil seal.
- (b) Apply MP grease to the lip of a new oil seal.
- (c) Using SST and a hammer, drive in a new oil seal.
SST 09950-60010 (09951-00270), 09950-70010 (09951-07150)

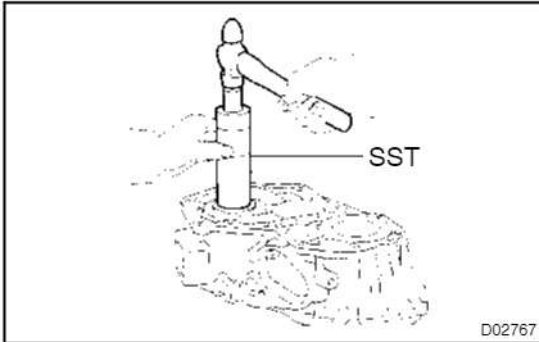

27. IF NECESSARY, REPLACE INPUT SHAFT OIL SEAL OF FRONT CASE

- (a) Using SST and a hammer, drive out the oil seal.
SST 09316-60011 (09316-00011)
- (b) Apply MP grease to the lip of a new oil seal.

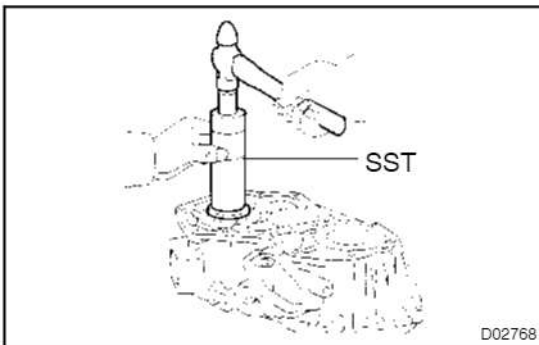

- (c) Using SST and a hammer, drive in a new oil seal.
SST 09316-60011 (09316-00011, 09316-00031)

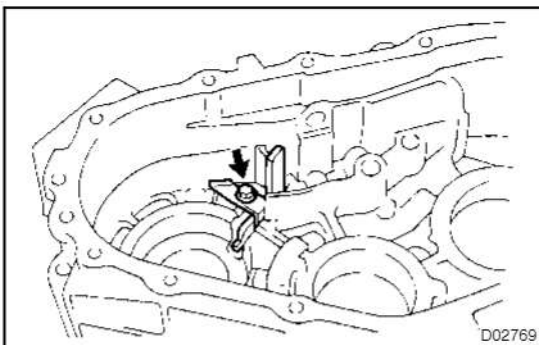

28. REMOVE OIL RECEIVER

Remove the bolt and oil receiver from the front case.

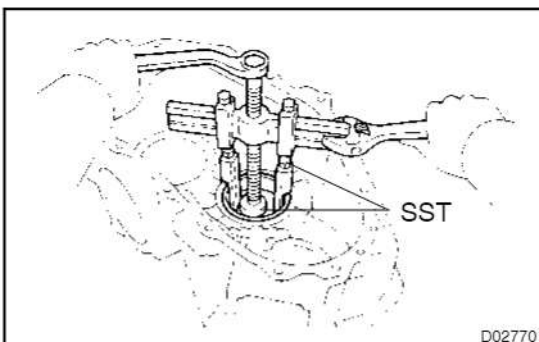

29. IF NECESSARY, REPLACE BEARING OUTER RACE OF FRONT CASE

- (a) Using SST, remove the bearing outer race (for the idler gear).
SST 09950-40011 (09951-04020, 09952-04010, 09953-04030, 09954-04010, 09955-04061, 09957-04010), 09950-60010 (09951-00320)

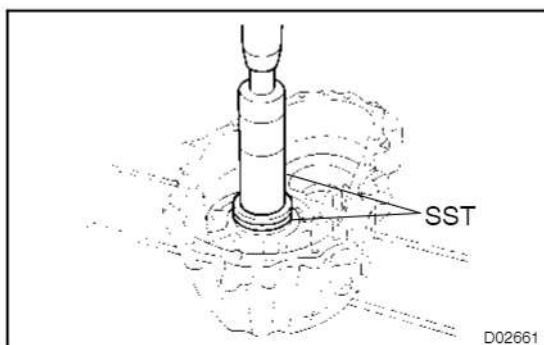

- (b) Using SST and a press, install the bearing outer race (for the idler gear).
 SST 09316-60011 (09316-00011, 09316-00031),
 09950-60020 (09951-00790)

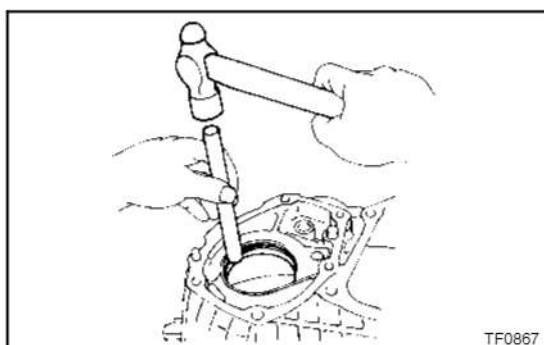

- (c) Using a brass bar and hammer, remove the bearing outer race (for the output shaft).

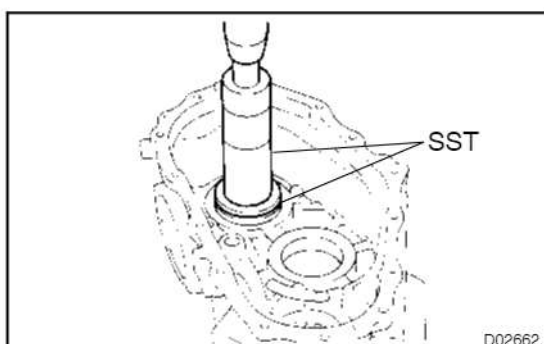

- (d) Using SST and a press, install the bearing outer race (for the output shaft).
 SST 09316-60011 (09316-00011, 09316-00031),
 09950-60020 (09951-00890)

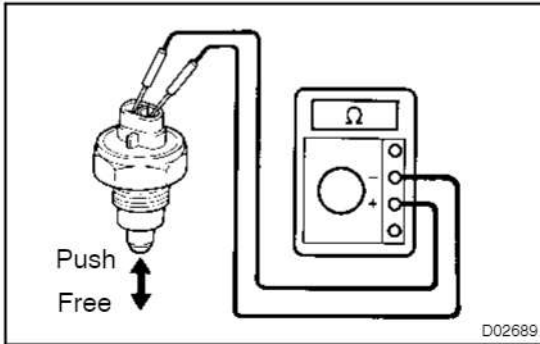

INSPECTION

1. INSPECT TRANSFER INDICATOR SWITCH

Check that continuity exists between the terminals, as shown.

Switch Position	Specified Condition
Push	Continuity
Free	No continuity

If continuity is not as specified, replace the switch.

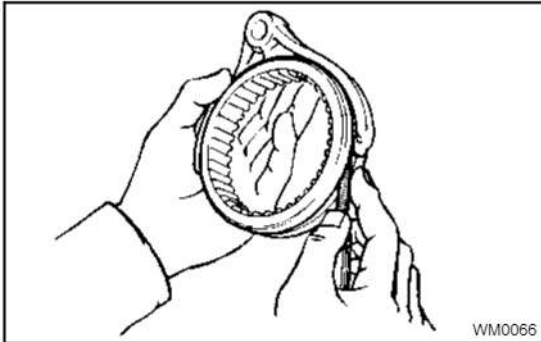

2. INSPECT NO. 2 SHIFT FORK AND FRONT DRIVE CLUTCH SLEEVE CLEARANCE

Using a feeler gauge, measure the clearance between the No. 2 shift fork and clutch sleeve.

Standard clearance: 0.1 – 0.4 mm (0.0039 – 0.0157 in.)

Maximum clearance: 0.4 mm (0.0157 in.)

If the clearance exceeds the maximum, replace the shift fork or clutch sleeve.

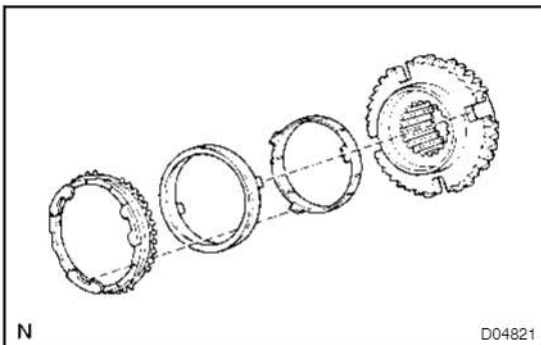

3. INSPECT NO. 2 SYNCHRONIZER OUTER RING, NO. 2 SYNCHRONIZER MIDDLE RING AND NO. 2 SYNCHRONIZER INNER RING

- Check for wear or damage.
- Install the No. 2 synchronizer inner ring, middle ring and outer ring to each gear.

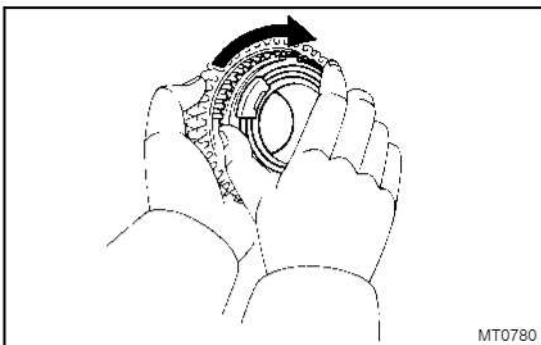

- Check the braking effect of the synchronizer ring. Turn the synchronizer ring in one direction while pushing it to the gear cone. Check that the ring locks.

If it does not lock, replace the synchronizer ring.

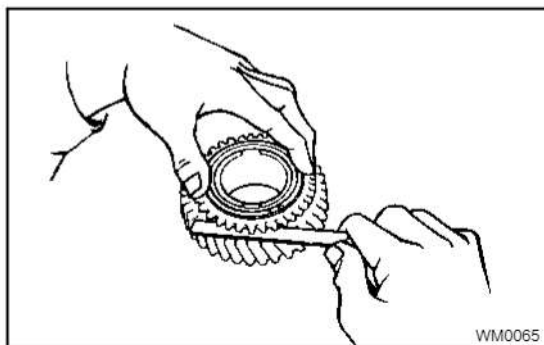

- (d) Using a feeler gauge, measure the clearance between the synchronizer ring back and gear spline end.

Standard clearance:

1.02 - 1.98 mm (0.0402 - 0.0780 in.)

Minimum clearance: 1.02 mm (0.0402 in.)

If the clearance is less than the minimum, replace the synchronizer ring, and apply a small amount of the fine lapping compound on gear cone.

NOTICE:

Ensure the fine lapping compound is completely washed off after rubbing.

REASSEMBLY

HINT:

Coat all of the sliding and rotating surfaces with gear oil before reassembly.

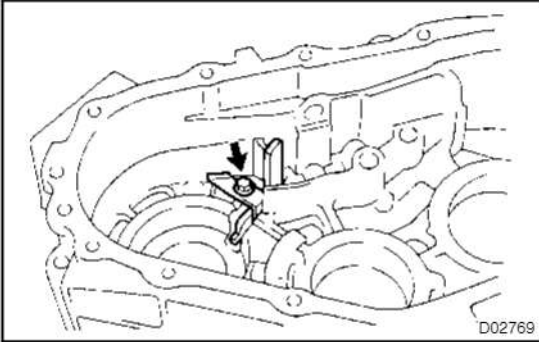

1. INSTALL OIL RECEIVER

Install the oil receiver to the front case with the bolt.

Torque: 12 N·m (120 kgf·cm, 9 ft·lbf)

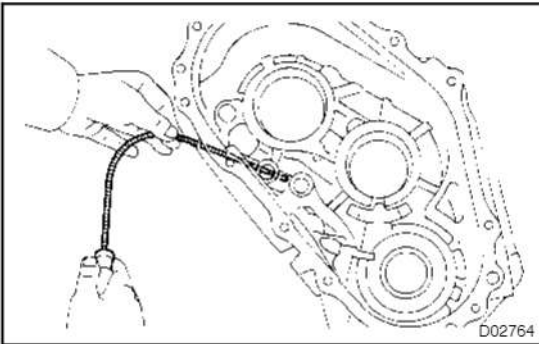

2. INSTALL STARTING PIN

Using a magnetic finger, install the straight pin to the front case.

3. INSTALL SHIFT INNER LEVER AND SHIFT INNER LEVER SHAFT

- (a) Assemble the shift inner lever and the shift inner lever shaft with the E-ring.
- (b) Install the shift inner lever and shift inner lever shaft to the front case.

4. INSTALL FRONT DRIVE SHIFT FORK SHAFT

- (a) Using pliers, install the snap ring to the front drive shift fork shaft.

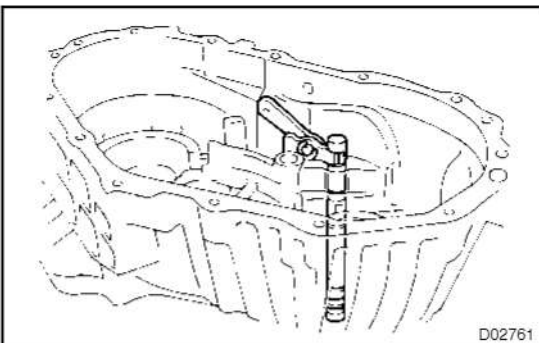

- (b) Install the front drive shift fork shaft to the front case.

NOTICE:

- **Set the shift inner lever into the fork head part of the front drive shift fork shaft securely.**

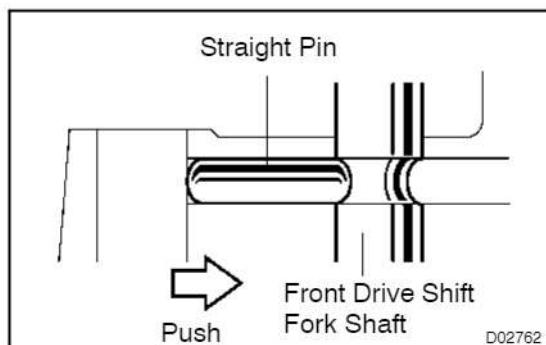

- After installing the front drive shift fork shaft, push the straight pin in the groove of the front drive shift fork shaft, as shown in the illustration.

5. INSTALL OUTPUT SHAFT ASSEMBLY TO FRONT CASE

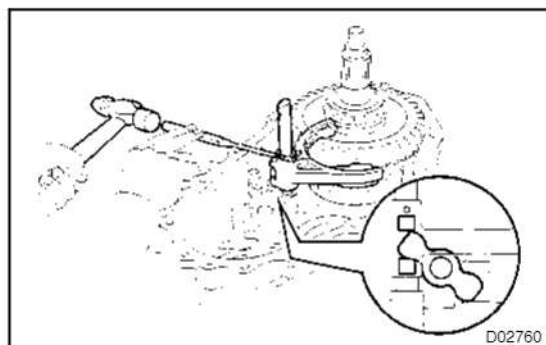

6. INSTALL NO. 1 SHIFT FORK AND HIGH AND LOW SHIFT FORK SHAFT

- Install the No. 1 shift fork and the high and low shift fork shaft.

NOTICE:

Set the shift inner lever into the fork head part of the No. 1 shift fork securely.

- Using a pin punch and hammer, drive in the slotted spring pin to the No. 1 shift fork.

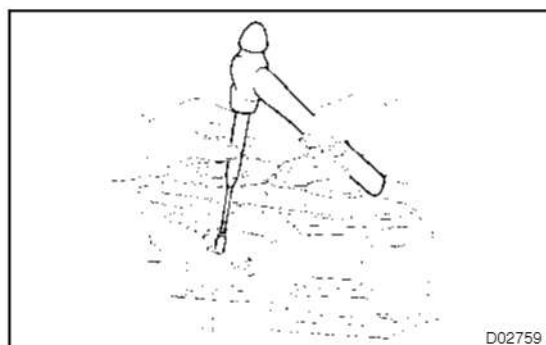

7. INSTALL SHIFT OUTER LEVER

- Install the shift outer lever to the shift inner lever.
- Using a pin punch and hammer, drive in the lever lock pin.

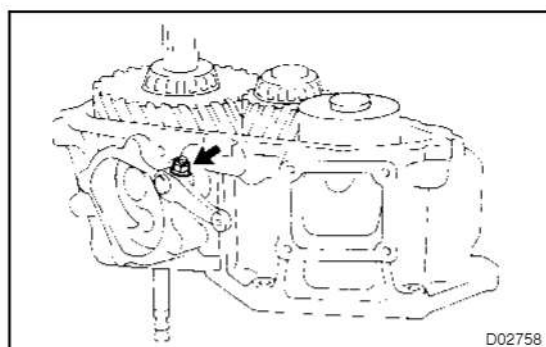

- Install the washer and nut.

Torque: 12 N·m (120 kgf·cm, 9 ft·lbf)

8. INSTALL IDLER GEAR ASSEMBLY TO FRONT CASE

HINT:

If it is difficult to install the idler gear assembly, pull up the output shaft assembly.

9. INSTALL INPUT SHAFT ASSEMBLY TO FRONT CASE

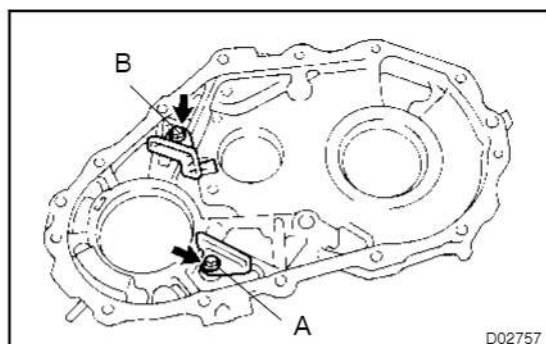

10. INSTALL OIL RECEIVER PIPE

Install the 2 oil receiver pipes to the rear case with the 2 bolts.

Torque:

Bolt A: 12 N·m (120 kgf·cm, 9 ft·lbf)

Bolt B: 18 N·m (185 kgf·cm, 13 ft·lbf)

11. INSTALL 2 BEARING OUTER RACES TO REAR CASE

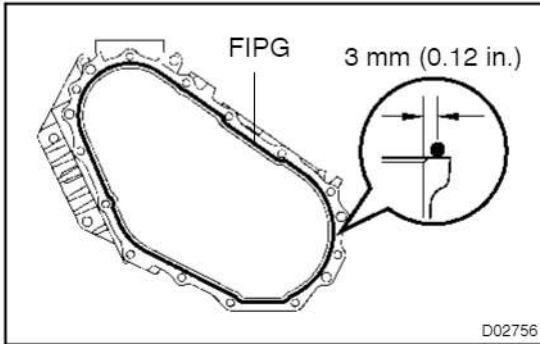

12. ASSEMBLE FRONT CASE AND REAR CASE

- (a) Apply FIPG to the front case.

FIPG:

Part No. 08826-00090, THREE BOND 1280 or equivalent

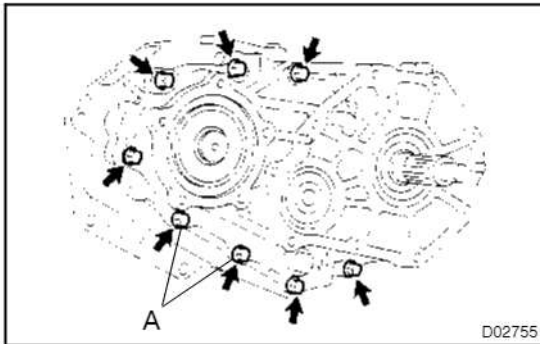

- (b) Apply sealant to the "A" bolt threads.

Sealant:

Part No. 08833-00080, THREE BOND 1344, LOCTITE 242 or equivalent

- (c) Install the rear case to the front case with the 8 bolts.

Torque: 37 N·m (380 kgf·cm, 27 ft·lbf)

- (d) Using a snap ring expander, install the snap ring to the input shaft.

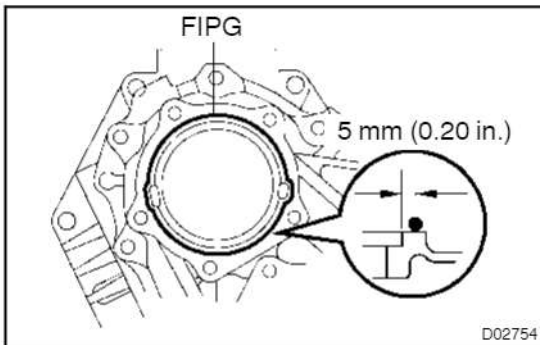

13. INSTALL CASE COVER

- (a) Apply FIPG to the rear case.

FIPG:

Part No. 08826-00090, THREE BOND 1281 or equivalent

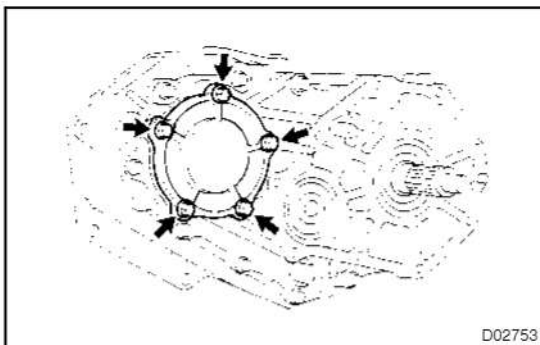

- (b) Apply sealant to the bolt threads.

Sealant:

Part No. 08833-00080, THREE BOND 1344, LOCTITE 242 or equivalent

- (c) Install the case cover to the rear case with the 5 bolts.

Torque: 37 N·m (380 kgf·cm, 27 ft·lbf)

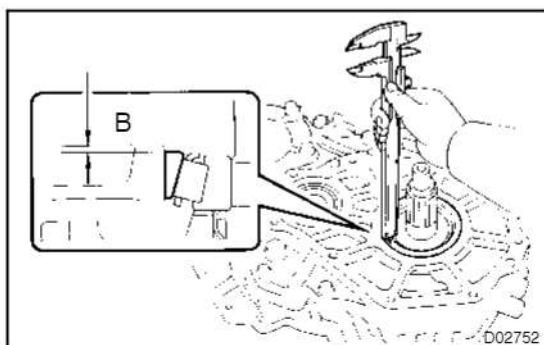

14. SELECT ADJUSTING SHIM FOR OUTPUT SHAFT TAPER ROLLER BEARING

- Using vernier calipers, measure the clearance of the dimension "B".
- Lightly hold down the bearing outer race in the thrust direction to eliminate any looseness before making the measurement.
- Calculate the required thickness of the adjusting shim.
Thickness: Dimension "B" + [0.070 - 0.034 mm (0.0028 - 0.0013 in.)]
- From the following table, select a shim so that its thickness is within the range of the calculation.

Mark	Thickness mm (in.)	Mark	Thickness mm (in.)
2	0.30 (0.0118)	8	1.80 (0.0709)
3	0.45 (0.0177)	9	2.00 (0.0787)
4	1.00 (0.0394)	10	2.20 (0.0866)
5	1.20 (0.0472)	11	2.40 (0.0945)
6	1.40 (0.0551)	12	2.60 (0.1024)
7	1.60 (0.0630)	13	0.55 (0.0216)

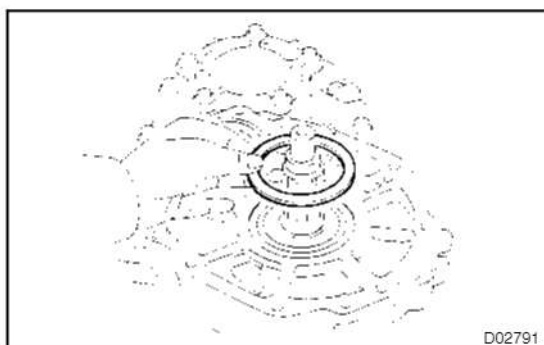

15. INSTALL ADJUSTING SHIM FOR OUTPUT SHAFT TAPER ROLLER BEARING

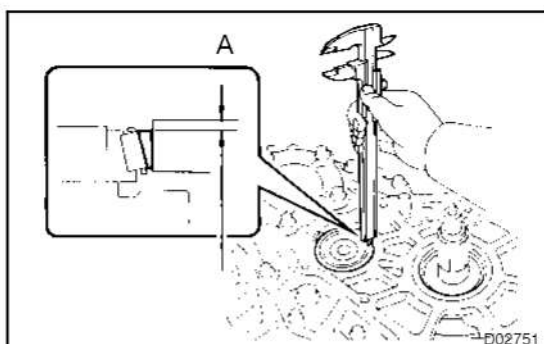

16. SELECT ADJUSTING SHIM FOR IDLER GEAR TAPER ROLLER BEARING

- Using vernier calipers, measure the clearance of the dimension "A".
- Lightly hold down the bearing outer race in the thrust direction to eliminate any looseness before making the measurement.
- Calculate the required thickness of the adjusting shim.
Thickness: Dimension "A" + [0.014 - 0.042 mm (0.0006 - 0.0017 in.)]
- From the following table, select a shim so that its thickness is within the range of the calculation.

Mark	Thickness mm (in.)	Mark	Thickness mm (in.)
2	0.30 (0.0118)	8	3.20 (0.1260)
3	0.45 (0.0177)	9	3.40 (0.1339)
4	2.40 (0.0945)	10	3.60 (0.1417)
5	2.60 (0.1024)	11	3.80 (0.1496)
6	2.80 (0.1102)	12	4.00 (0.1575)
7	3.00 (0.1181)	13	0.55 (0.0216)

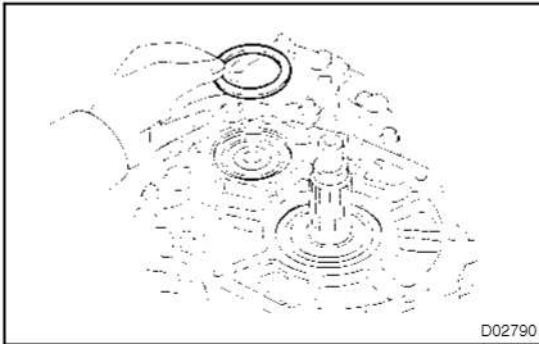

17. **INSTALL ADJUSTING SHIM FOR IDLER GEAR TAPER ROLLER BEARING**



18. **INSTALL SPACER TO OUTPUT SHAFT**

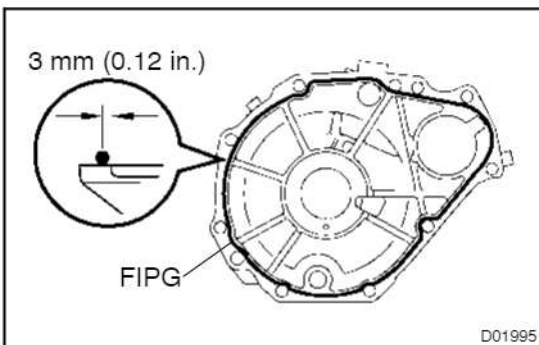

19. **INSTALL REAR EXTENSION HOUSING**

- (a) Apply FIPG to the rear extension housing.

FIPG:

Part No. 08826-00090, THREE BOND 1281 or equivalent

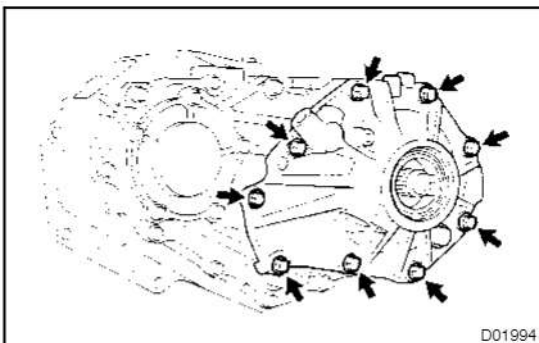

- (b) Install the rear extension housing with the 9 bolts.
Torque: 37 N·m (380 kgf·cm, 27 ft·lbf)

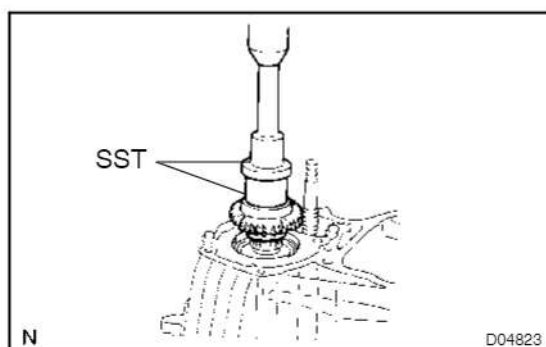

20. INSTALL FRONT DRIVE GEAR PIECE

- (a) Using SST and a press, install the front drive gear piece to the output shaft.

SST 09517-12010, 09631-20081

- (b) Select a snap ring that allows the minimum axial play.

Mark	Thickness mm (in.)	Mark	Thickness mm (in.)
A	2.00 (0.0787)	D	2.30 (0.0906)
B	2.10 (0.0827)	E	2.40 (0.0945)
C	2.20 (0.0866)	-	-

- (c) Using a snap ring expander, install a new snap ring.

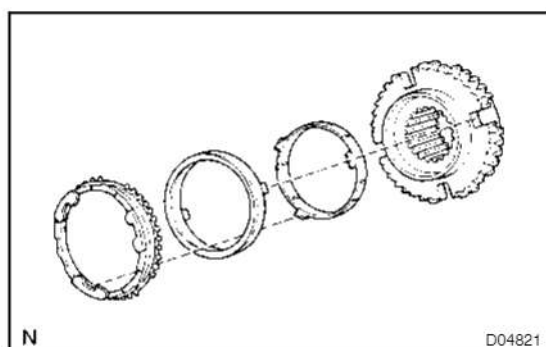

21. INSTALL NO. 2 SYNCHRONIZER INNER RING, NO. 2 SYNCHRONIZER MIDDLE RING AND NO. 2 SYNCHRONIZER OUTER RING

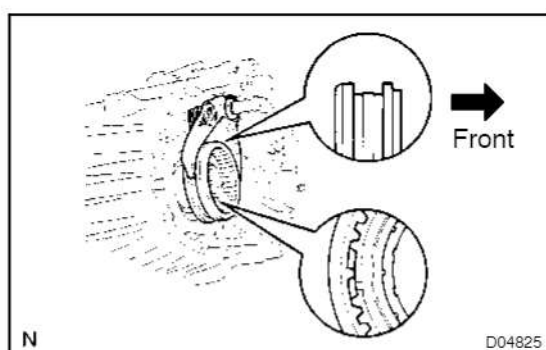

22. INSTALL FRONT DRIVE CLUTCH SLEEVE AND NO. 2 SHIFT FORK

- (a) Install the front drive clutch sleeve, compression spring, 2 plate washers and No. 2 shift fork.

HINT:

Make sure to install the front drive clutch sleeve in the correct direction.

NOTICE:

Assemble the front drive clutch sleeve and No. 2 synchronizer outer ring securely to ensure they are in the position as shown in the illustration.

- (b) Using pliers, install the snap ring to the front drive shift fork shaft.

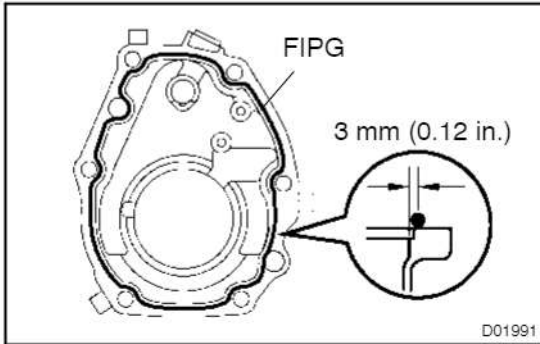
**23. INSTALL FRONT EXTENSION HOUSING**

- (a) Apply FIPG to the front extension housing.

FIPG:

Part No. 08826-00090, THREE BOND 1281 or equivalent

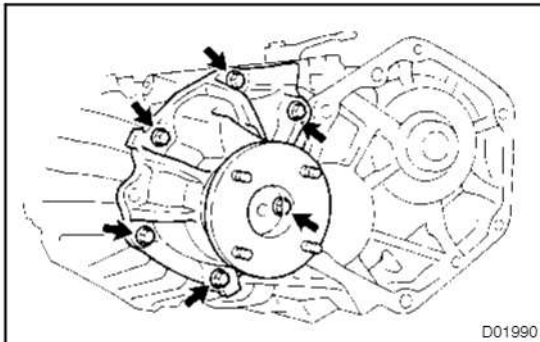

- (b) Install the front extension housing with the 6 bolts.
Torque: 37 N·m (380 kgf·cm, 27 ft·lbf)

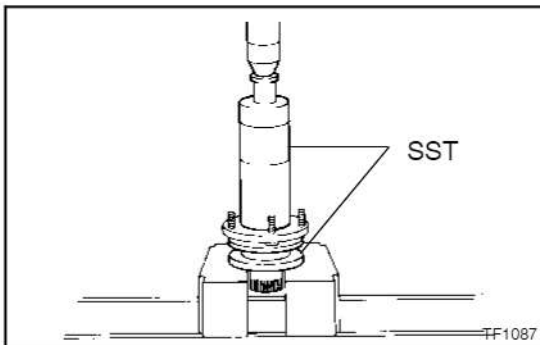
**24. INSTALL OUTPUT SHAFT COMPANION FLANGE**

- (a) Using SST and a press, install the dust deflector to the companion flange.

SST 09316-20011, 09316-60011 (09316-00011)

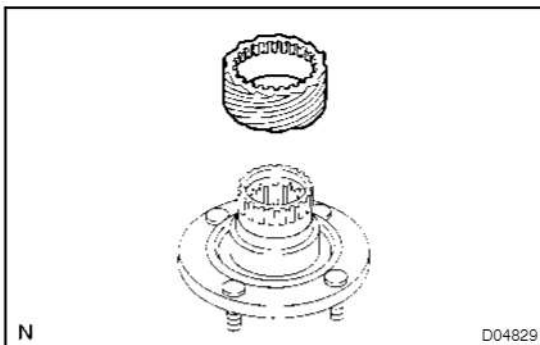

- (b) Install the speed sensor drive gear to the companion flange.

HINT:

Align the companion flange grooves with the projections on the speed sensor drive gear.

- (c) Install the companion flange.

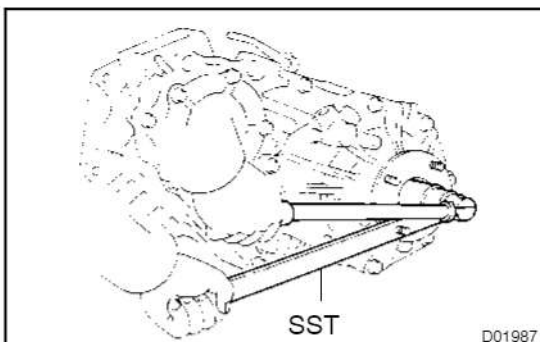

- (d) Using SST to hold the flange, install a new O-ring and nut.

SST 09330-00021

Torque: 127 N·m (1,300 kgf·cm, 94 ft·lbf)

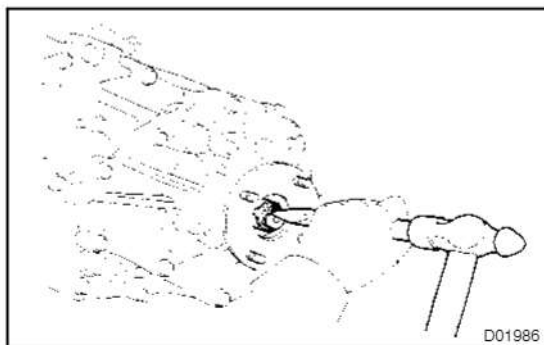

(e) Using a chisel and hammer, stake the nut.

25. INSTALL TRANSFER INDICATOR SWITCH

Install 3 new gaskets, transfer 4WD position switch, L4 position switch and neutral position switch.

Torque: 37 N·m (380 kgf·cm, 27 ft·lbf)

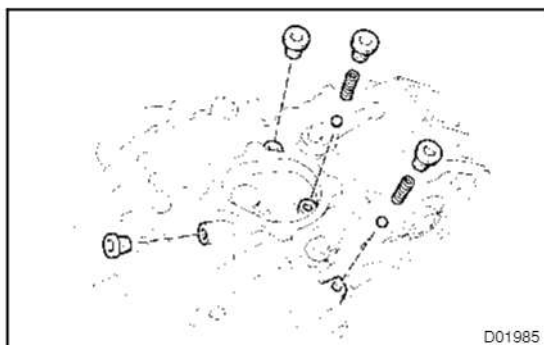

26. INSTALL SCREW PLUG, SPRING AND BALL

(a) Install the 2 balls and springs.

(b) Apply sealant to the screw plug threads.

Sealant:

Part No. 08833-00080, THREE BOND 1344, LOCTITE 242 or equivalent

(c) Using a torx socket wrench (T40), install the 4 screw plugs.

Torque: 19 N·m (190 kgf·cm, 14 ft·lbf)

27. INSTALL SPEED SENSOR DRIVEN GEAR

Install the speed sensor driven gear with the bolt.

Torque: 11 N·m (115 kgf·cm, 8 ft·lbf)

28. INSTALL BREATHER HOSE

OUTPUT SHAFT COMPONENTS

TR091-01

w/ Dual mode automatic locking hub:

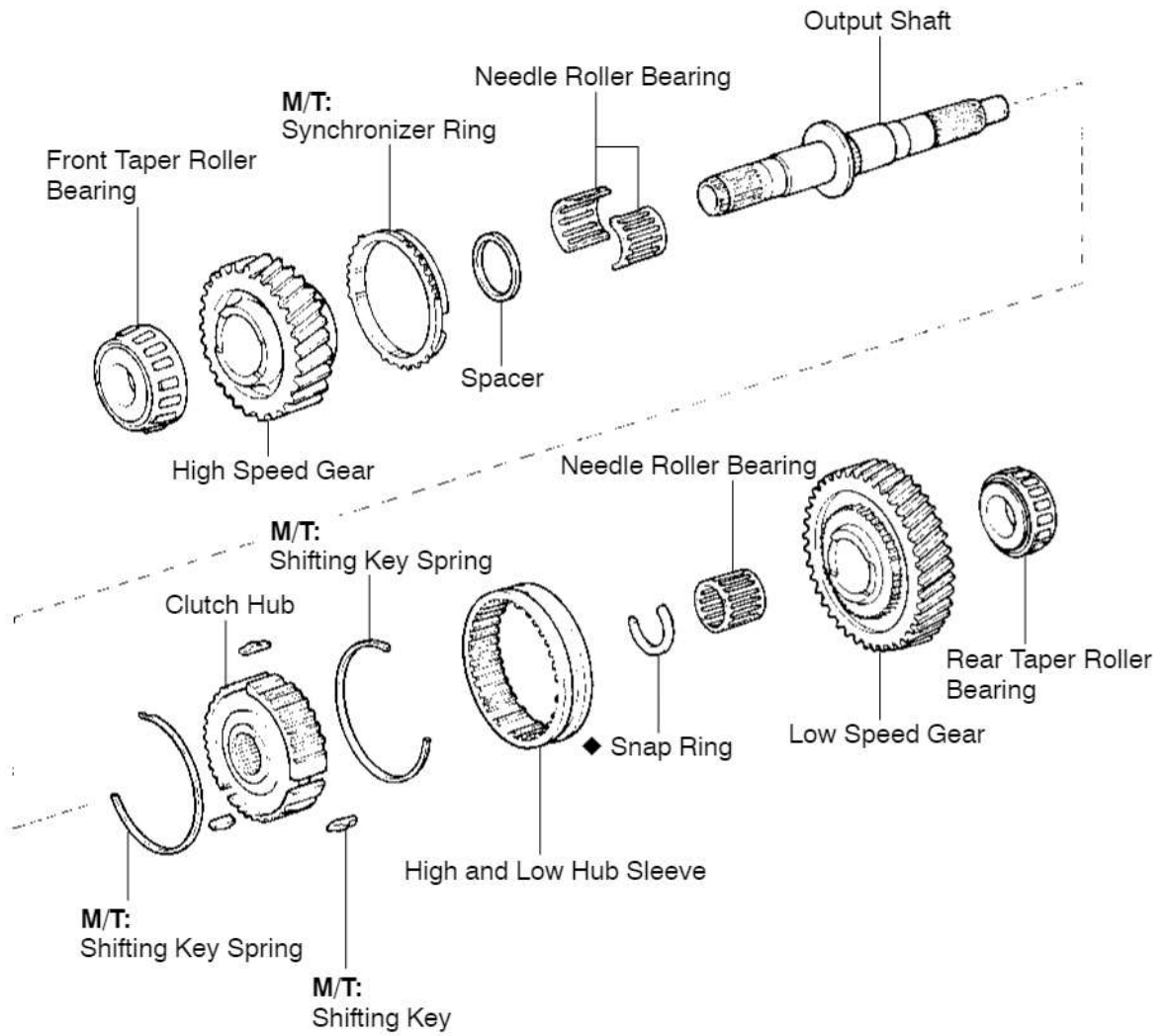

◆ Non-reusable part

D04830

cardiagn.com

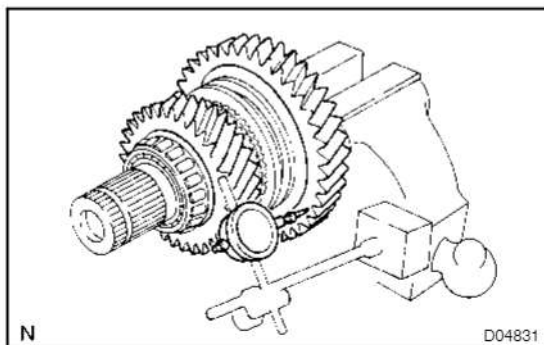

DISASSEMBLY

1. MEASURE EACH GEAR THRUST CLEARANCE

Using a dial indicator, measure the thrust clearance of the high speed gear and low speed gear.

High speed gear

Standard clearance:

0.28 – 0.43 mm (0.0110 – 0.0169 in.)

Maximum clearance: 0.43 mm (0.0169 in.)

Low speed gear

Standard clearance:

0.20 – 0.45 mm (0.0079 – 0.0177 in.)

Maximum clearance: 0.45 mm (0.0177 in.)

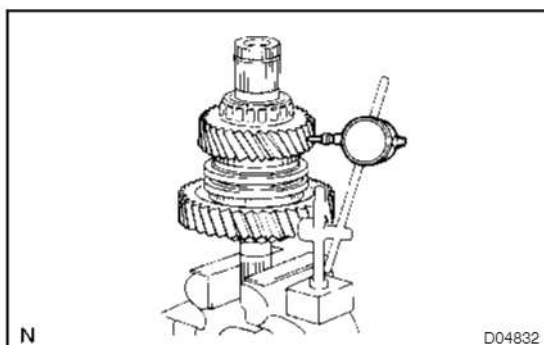

2. MEASURE EACH GEAR RADIAL CLEARANCE

Using a dial indicator, measure the radial clearance of the high speed gear and low speed gear.

Standard clearance:

0.015 – 0.068 mm (0.0005 – 0.0027 in.)

Maximum clearance: 0.068 mm (0.0027 in.)

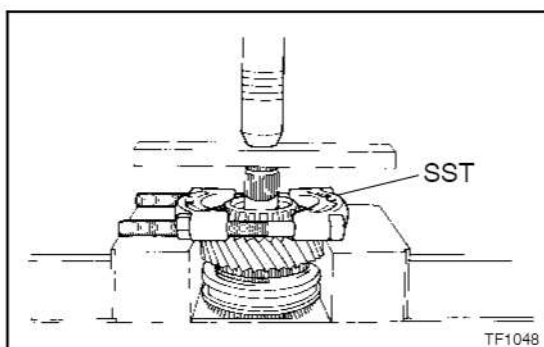

3. REMOVE FRONT TAPER ROLLER BEARING

Using SST and a press, remove the front taper roller bearing.
SST 09950-00020

NOTICE:

- Support the output shaft assembly by hand so that it will not be dropped off.
 - Set the claw of SST to the bearing inner race securely.
- ### 4. REMOVE HIGH SPEED GEAR, SYNCHRONIZER RING (M/T), NEEDLE ROLLER BEARING AND SPACER

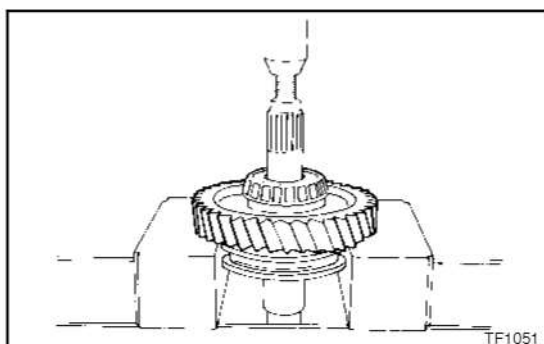

5. REMOVE REAR TAPER ROLLER BEARING AND LOW SPEED GEAR

- (a) Using a press, remove the rear taper roller bearing and low speed gear.
- (b) Remove the needle roller bearing.

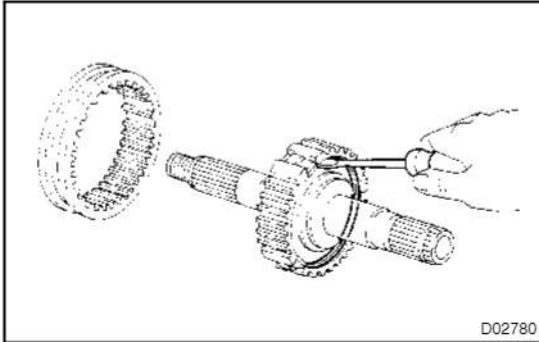
**6. REMOVE HIGH AND LOW HUB SLEEVE**

- (a) Remove the high and low hub sleeve.
- (b) M/T:
Using a screwdriver, remove the 2 shifting key springs.
- (c) M/T:
Remove the 3 shifting keys from the clutch hub.

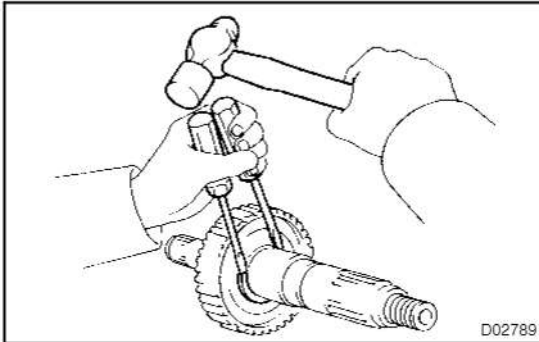
**7. REMOVE CLUTCH HUB**

- (a) Using 2 screwdrivers and a hammer, drive out the snap ring.

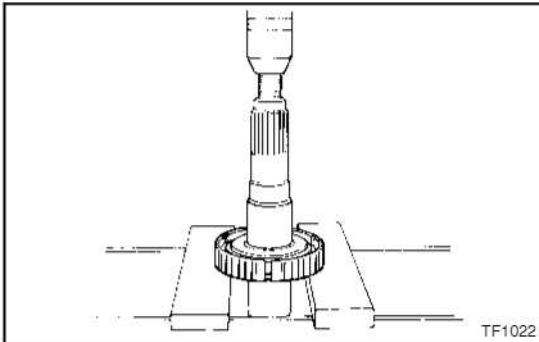

- (b) Using a press, remove the clutch hub.

REASSEMBLY

HINT:

Coat all of the sliding and rotating surfaces with gear oil before reassembly.

1. **A/T:**
INSTALL CLUTCH HUB INTO HIGH AND LOW HUB SLEEVE

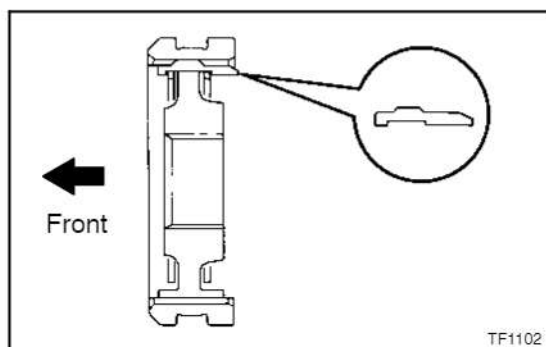

2. **M/T:**
INSTALL CLUTCH HUB INTO HIGH AND LOW HUB SLEEVE

- (a) Install the clutch hub and 3 shifting keys to the high and low hub sleeve.
- (b) Install the 2 shifting key springs under the shifting keys.

NOTICE:

Position the key springs so that their end gaps are not aligned.

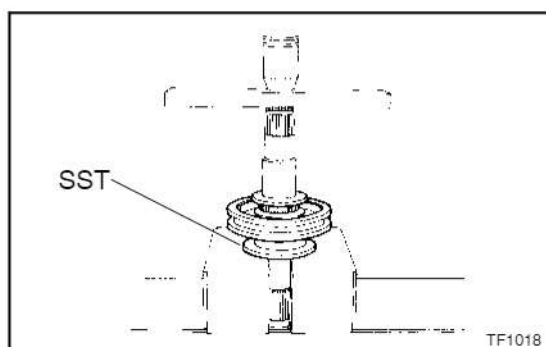

3. **INSTALL HIGH AND LOW HUB SLEEVE ASSEMBLY**
- (a) Using SST and a press, install the high and low hub sleeve assembly to the output shaft.
SST 09316-20011

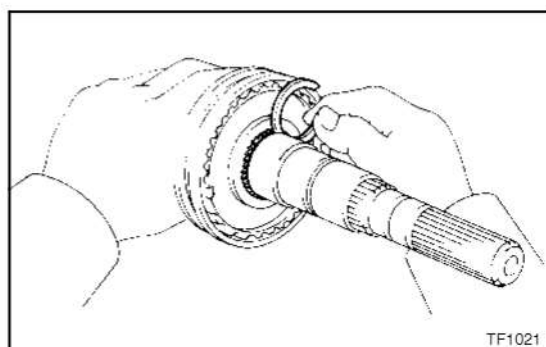

- (b) Select a snap ring that allows the minimum axial play.

Mark	Thickness mm (in.)	Mark	Thickness mm (in.)
A	2.60 (0.1024)	E	2.80 (0.1102)
B	2.65 (0.1043)	F	2.85 (0.1122)
C	2.70 (0.1063)	G	2.90 (0.1142)
D	2.75 (0.1083)	-	-

- (c) Using a snap ring expander, install a new snap ring.

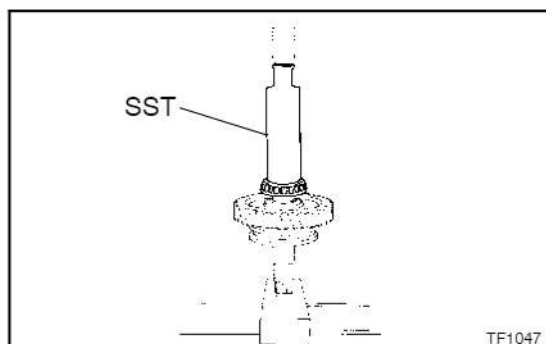

4. **INSTALL NEEDLE ROLLER BEARING, LOW SPEED GEAR AND REAR TAPER ROLLER BEARING**

- (a) Apply gear oil to the needle roller bearing.
- (b) Install the needle roller bearing and low speed gear.
- (c) Using SST and a press, install the rear taper roller bearing.
SST 09316-60011 (09316-00011)

5. INSTALL SPACER, NEEDLE ROLLER BEARING, SYNCHRONIZER RING (M/T) AND HIGH SPEED GEAR

- (a) Apply gear oil to the needle roller bearing.
- (b) Install the spacer, needle roller bearing, synchronizer ring (M/T) and high speed gear.

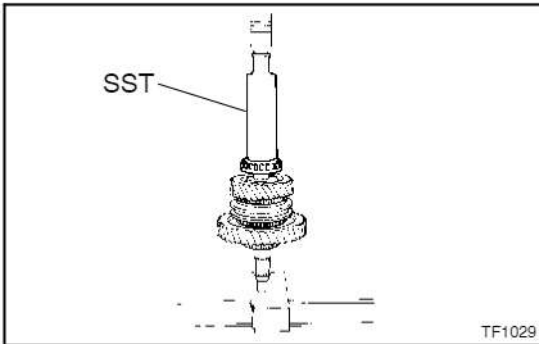
NOTICE:**M/T:****Align the ring slots with the shifting keys.****6. INSTALL FRONT TAPER ROLLER BEARING**

Using SST and a press, install the front taper roller bearing.

SST 09316-60011 (09316-00011)

FRONT EXTENSION HOUSING COMPONENTS

TR094-01

w/ Dual mode automatic locking hub:

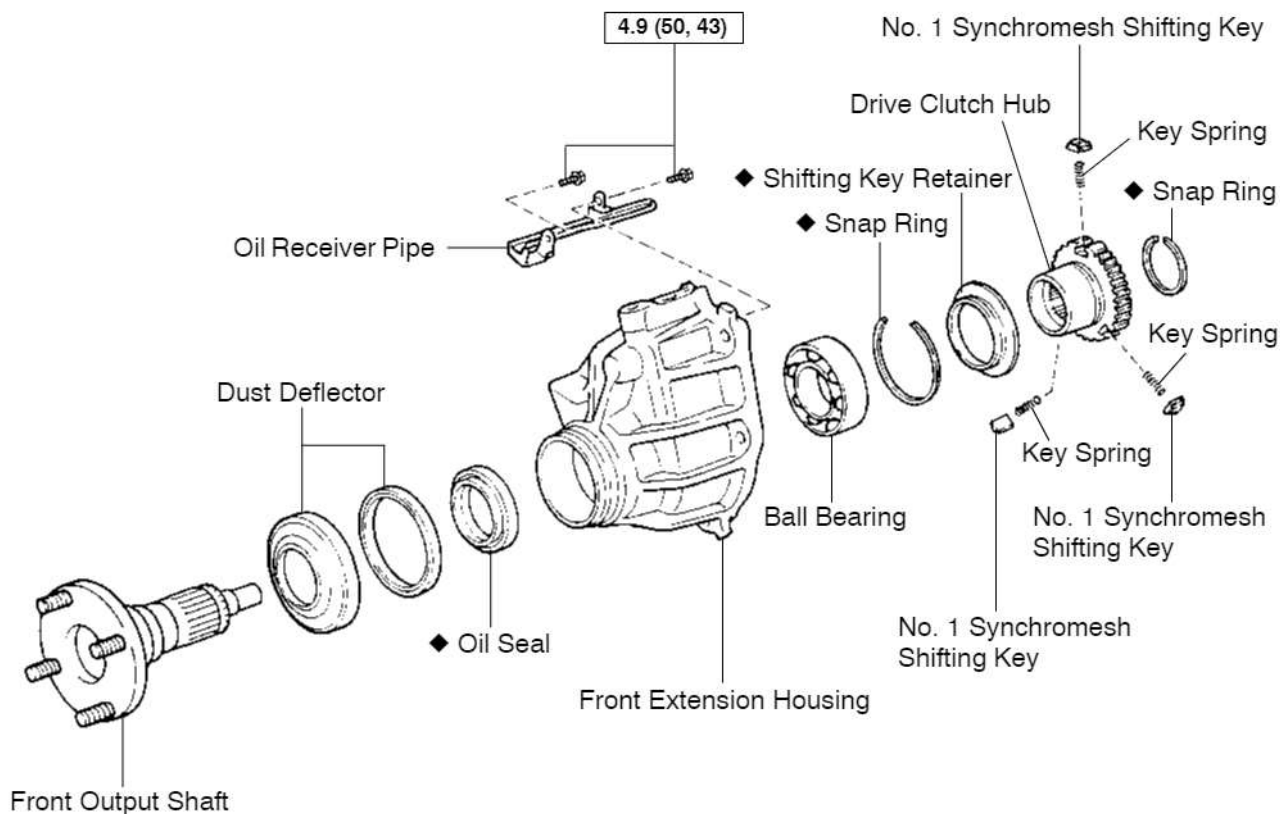

N·m (kgf·cm, in.·lbf) : Specified torque

◆ Non-reusable part

N

D04812

cardiagn.com

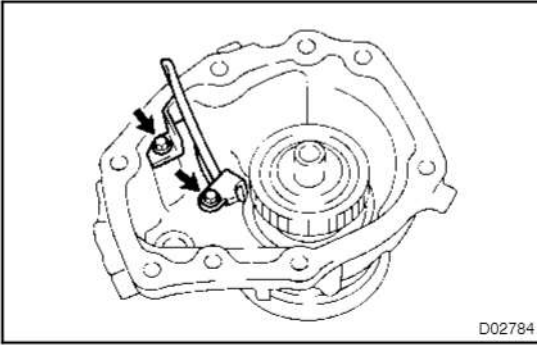

DISASSEMBLY

1. REMOVE OIL RECEIVER PIPE

Remove the 2 bolts and oil receiver pipe.

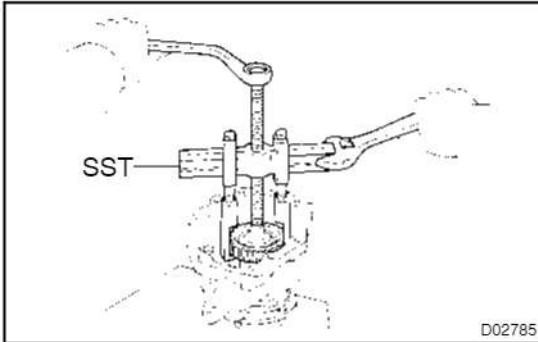

2. REMOVE DRIVE CLUTCH HUB

(a) Using a snap ring expander, remove the snap ring.

(b) Using SST, remove the drive clutch hub.

SST 09950-40011 (09951-04020, 09952-04010, 09953-04030, 09954-04010, 09955-04021)

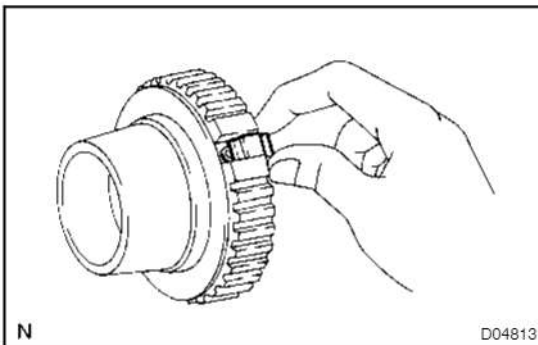

(c) Remove the 3 No. 1 synchromesh shifting keys and springs from the drive clutch hub.

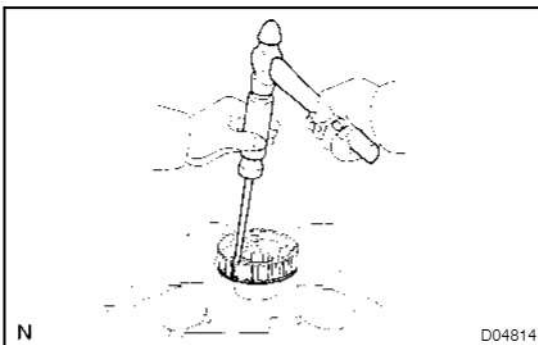

(d) Mount the drive clutch hub in a vise.

(e) Using a screwdriver and hammer, tap the shifting key retainer from the drive clutch hub and remove it.

3. REMOVE FRONT OUTPUT SHAFT

Using a plastic hammer, tap the front output shaft and remove it.

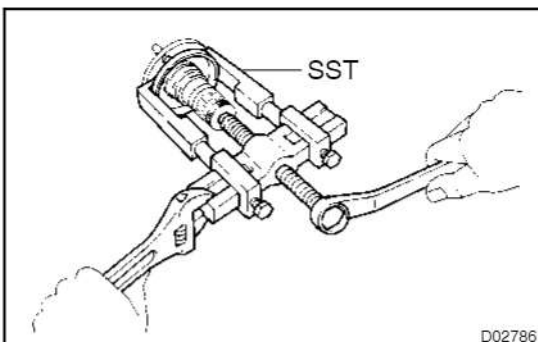

4. REMOVE DUST DEFLECTOR

(a) Using SST, remove the dust deflector from the front output shaft.

SST 09950-40011 (09951-04020, 09952-04010, 09953-04030, 09954-04010, 09955-04051, 09957-04010)

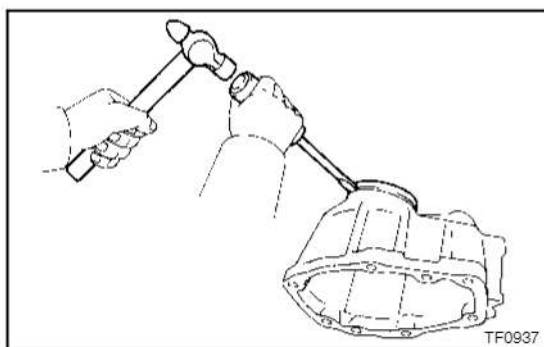

- (b) Using a screwdriver and hammer, tap the dust deflector from the front extension housing and remove it.

5. REMOVE OIL SEAL

Using a screwdriver, pry out the oil seal from the front extension housing.

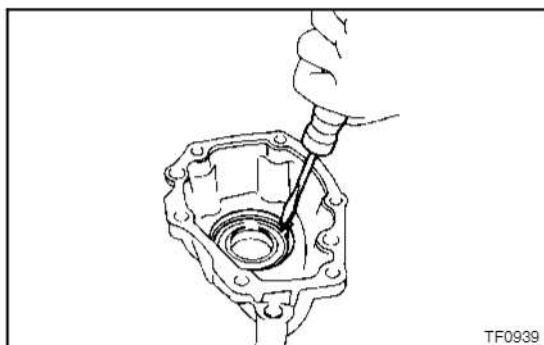

6. REMOVE BALL BEARING

- (a) Using a screwdriver, remove the snap ring from the front extension housing.

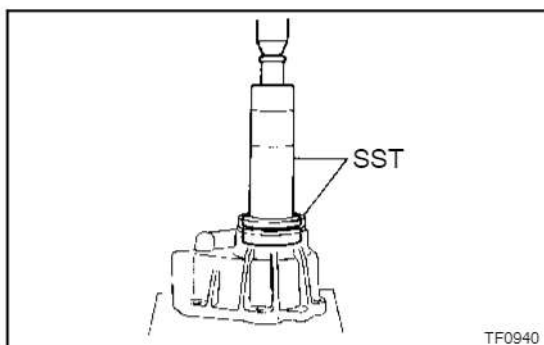

- (b) Using SST and a press, remove the ball bearing.
SST 09316-60011 (09316-00011, 09316-00071)

REASSEMBLY

HINT:

Coat all of the sliding and rotating surfaces with gear oil before reassembly.

1. INSTALL DUST DEFLECTOR

- (a) Using a plastic hammer, install the dust deflector to the front extension housing.

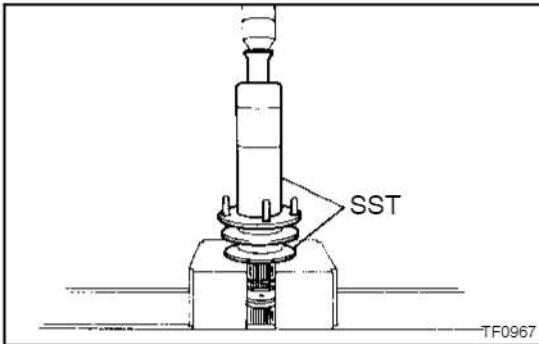

- (b) Using SST and a press, install the dust deflector to the front output shaft.

SST 09316-20011, 09316-60011 (09316-00011)

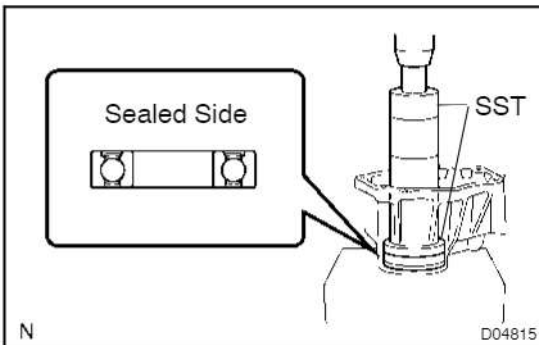

2. INSTALL BALL BEARING

- (a) Using SST and a press, install the ball bearing.

SST 09316-60011 (09316-00011, 09316-00031)

NOTICE:

As shown in the illustration, assemble the ball bearing paying attention to the sealing direction.

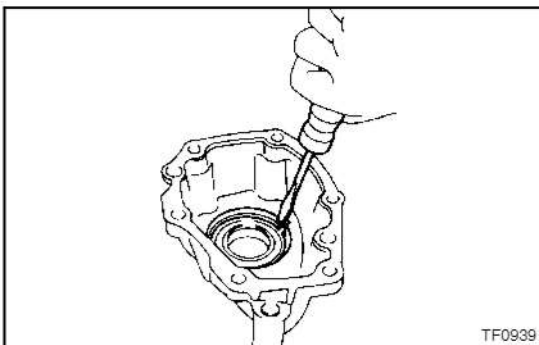

- (b) Select a snap ring that allows the minimum axial play.

Mark	Thickness mm (in.)
A	1.70 (0.0669)
B	1.80 (0.0709)

- (c) Using a screwdriver, install a new snap ring.

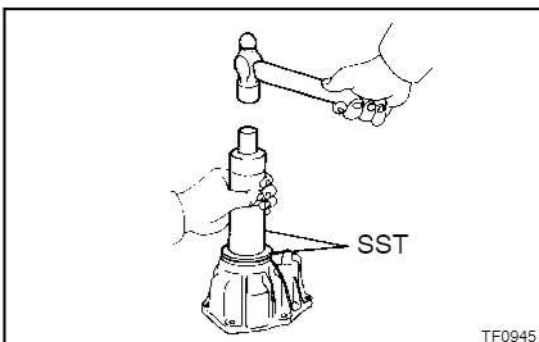

3. INSTALL OIL SEAL

- (a) Apply MP grease to the lip of a new oil seal.
- (b) Using SST and a hammer, drive in a new oil seal to the front extension housing.

SST 09316-60011 (09316-00011, 09316-00061)

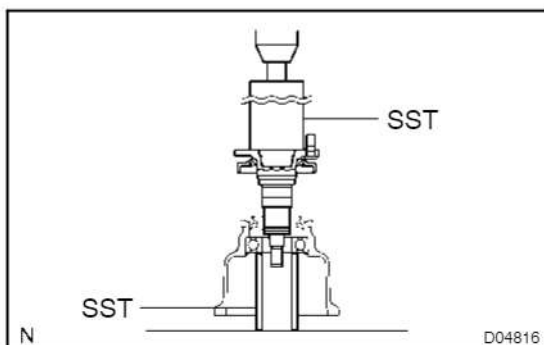

4. INSTALL FRONT OUTPUT SHAFT

Using SST and a press, install the front output shaft.

SST 09309-60010, 09316-60011 (09316-00011)

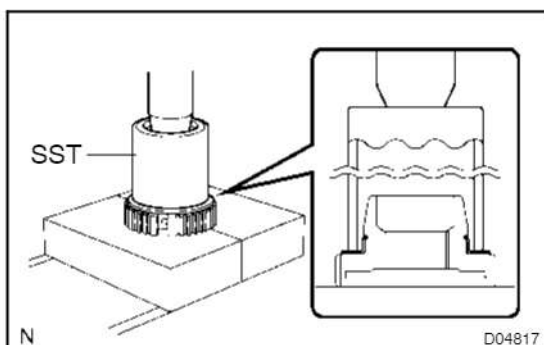

5. INSTALL DRIVE CLUTCH HUB

(a) Using SST and a press, install a new shifting key retainer to the drive clutch hub.

SST 09649-17010

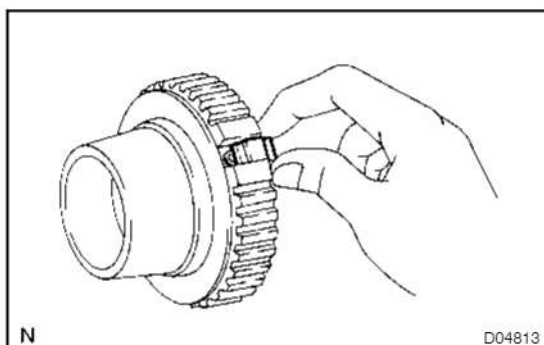

(b) Install the 3 key springs and No. 1 synchromesh shifting keys to the drive clutch hub.

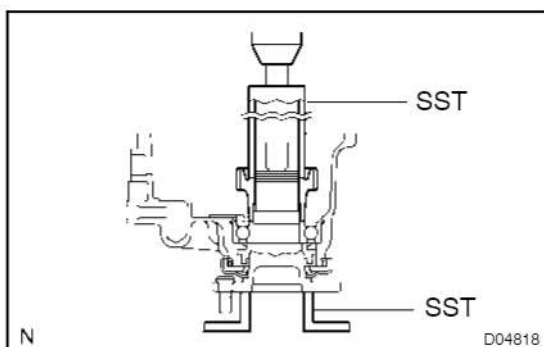

(c) Using SST and a press, install the drive clutch hub assembly to the front output shaft.

SST 09316-20011, 09316-60011 (09316-00011)

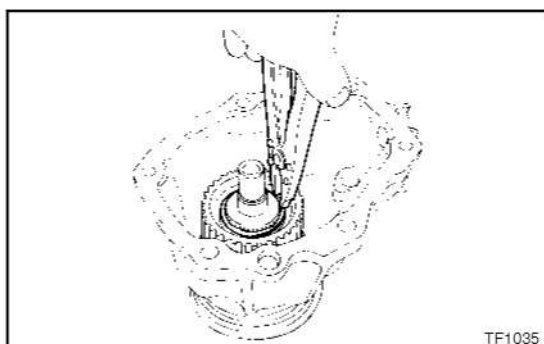

(d) Select a snap ring that allows the minimum axial play.

Mark	Thickness mm (in.)	Mark	Thickness mm (in.)
A	2.00 (0.0787)	D	2.30 (0.0906)
B	2.10 (0.0827)	E	2.40 (0.0945)
C	2.20 (0.0866)	-	-

(e) Using a snap ring expander, install a new snap ring.

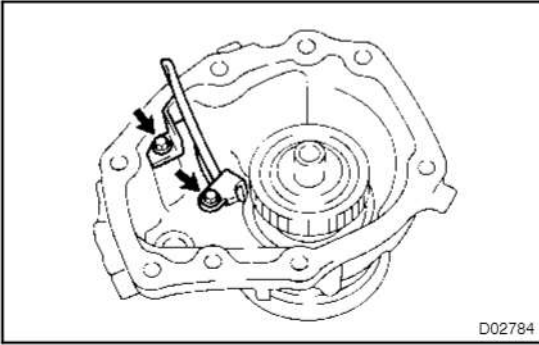
**6. INSTALL OIL RECEIVER PIPE**

Install the oil receiver pipe to the front extension housing with the 2 bolts.

Torque: 4.9 N·m (50 kgf·cm, 43 in·lbf)